

**Reservedele • Spare parts
Ersatzteile • Pièces détachées**

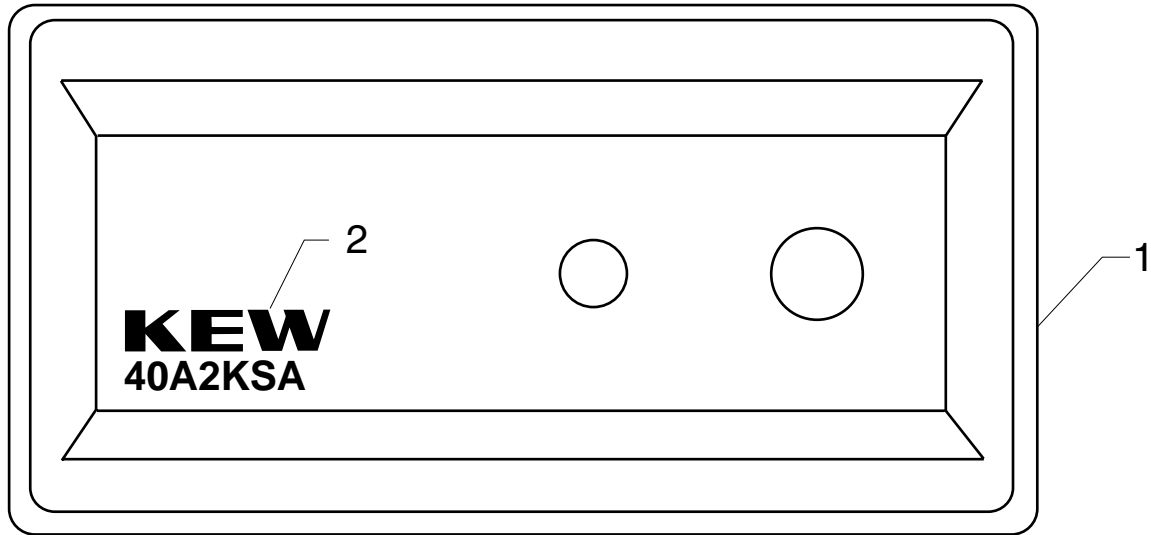

Kabinet, kompl. Cabinet, compl. / Haube, kompl. / Capot, compl.



Maskine, monteret / Machine, mounted / Maschine, montiert / Appareil, monté

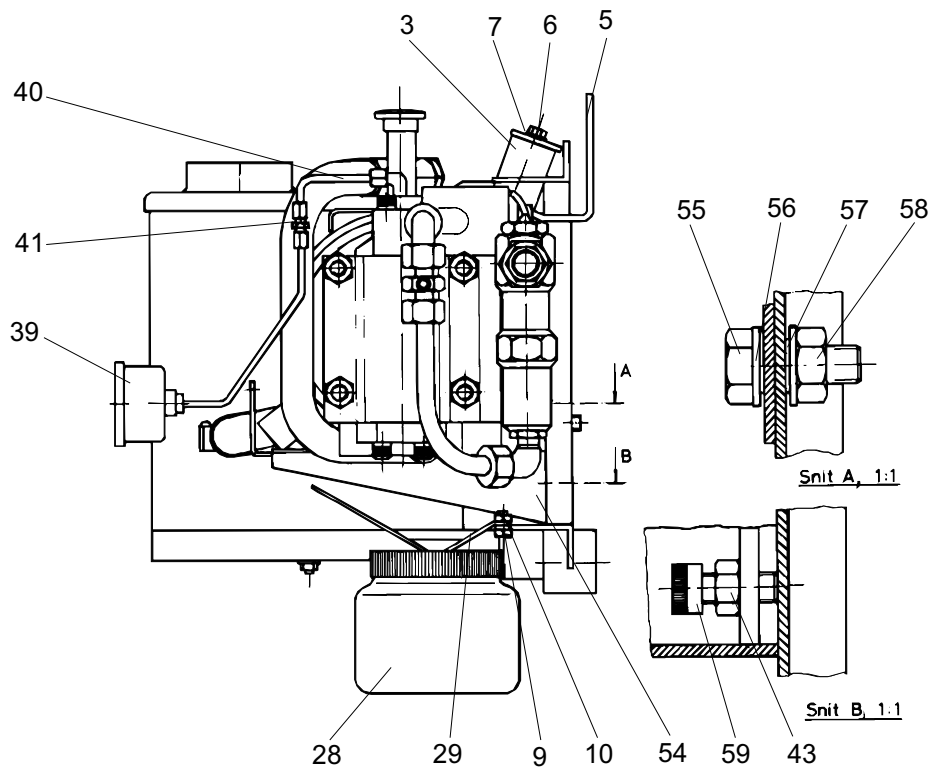
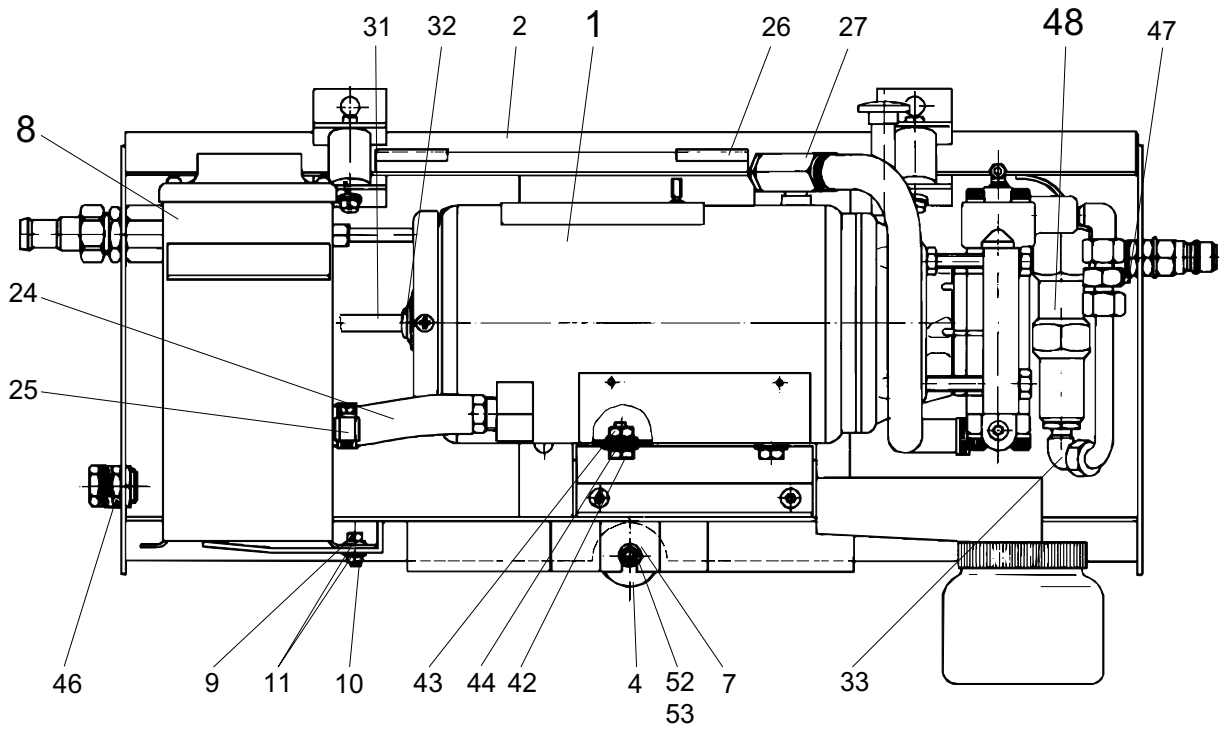

Pos. Ref.	Nr. No.	Betegnelse Bezeichnung	Designation Désignation	17A2KSA	40A2KSA
-	-	Maskine, monteret Machine, mounted Maschine, montiert Appareil, monté		x	x
1	-	Motorpumpeenhed, komp. Motor/pump unit, compl. Motorpumpeneinheit, kompl. Corps de moteur/pompe, compl.	Se side 10 See page 10 SieheSeite 10 Voir page 10		
2	6350251	Stel Chassis Rahmen Châssis		1	1
3	1803048	Svingningsdæmper Vibration damper Druckspeicher Amortisseur d'oscillations		2	2
4	1803097	Svingningsdæmper Vibration damper Druckspeicher Amortisseur d'oscillations		1	1
5	6350105	Vægophæng Fittings f. wall mounting Wandhalter Garniture p. fixation murale		2	2
6	1810266	Skrue Screw Schraube Vis		5	5
7	1801398	Skive Washer Scheibe Rondelle		5	5
8	6350465	Svømmerhus, kompl. Water tank, compl. Schwimmergehäuse, kompl. Bac à flotteur, compl.	Se side 14 See page 14 SieheSeite 14 Voir page 14		
9	1800721	Skrue Screw Schraube Vis		2	2
10	1800705	Møtrik Nut Mutter Ecrou		2	2
11	1800440	Skive Washer Scheibe Rondelle		4	4
12	6350460	Vandtilgang Water inlet Wassereinlaß Admission eau		1	1
13	6100941	Filter Filter Filter Filtre		1	1
14	1800341	Kontramøtrik Lock nut Gegenmutter Contre-écrou		1	1
15	6350364	Omløber Union nut Überwurfmutter Ecrou-raccord		1	1
16	6350363	Slangestuds Socket f. hose Schlauchstutzen Raccord du flexible		1	1
17	6350367	Pakning Gasket Dichtung Joint		1	1
18	6105345	Ventilsæde Valve seat Ventilsitz Siège du clapet		1	1
19	3001419	O-ring O-ring O-Ring Joint torique		1	1

Pos. Ref.	Nr. No.	Betegnelse Bezeichnung	Designation Désignation	17A2KSA	40A2KSA
20	6100620	Ventilkegle, sug Valve cone, suction Ventilkegel, Saug Cône du clapet d'aspiration		1	1
21	6100623	Ventilstyr, sug Valve guide, suction Ventilführung, Saug Guide du clapet d'aspiration		1	1
22	2600245	Fjeder Spring Feder Ressort		1	1
23	1803493	Tætningsskive Sealing washer Dichtungsscheibe Rondelle d'étanchéité		2	2
24	2403277	Slange Hose Schlauch Flexible		1	1
25	1802107	Spændebånd Hose clip Schlauchschelle Collier de serrage		1	2
26	6350115	Gummiliste Rubber gasket Gummidichtung Joint en caoutchouc		2	2
28	2200467	Slamglas Sludge container Schlammglas Reservoir d'huile usée		1	1
29	6352250	Slamglaslæg Cover f. sludge container Deckel f. Schlammglas Reservoir d'huiles usée		1	1
31	2402881	Slange Hose Schlauch Tuyau		1	1
32	3803780	Gummipakdåse Cable grommet Stopfbuchse Presse-étoupe	TET 10-14 C	1	1
33	6352452	Afgangsrør Outlet tube Auslaßrohr Tube de sortie		1	1
34	6200484	Skrotforskrning Threaded connection Verschraubung Raccord fileté		1	1
35	1803220	Kontramøtrik Lock nut Gegenmutter Contre-écrou		1	1
36	1801075	Tætningsskive Sealing washer Dichtungsscheibe Rondelle d'étanchéité		1	1
37	1600493	Lynkoblingsnippel (højtryk) Nipple f. quick coupling (h.p.) Nippel f. Schnellkuplung (H.D.) Entrée du coupleur rapide (h.d.)		1	1
38	6101038	Stempel Piston Kolben Piston		1	1
39	6352451	Manometer Pressure gauge Manometer Manomètre		1	1
40	6352450	Manometerør Tube f. pressure gauge Manometerrohr Tube p. manomètre		1	1
41	1603992	Forskrning Threaded connection Verschraubung Raccord fileté		1	1

Maskine, monteret / Machine, mounted / Maschine, montiert / Appareil, monté

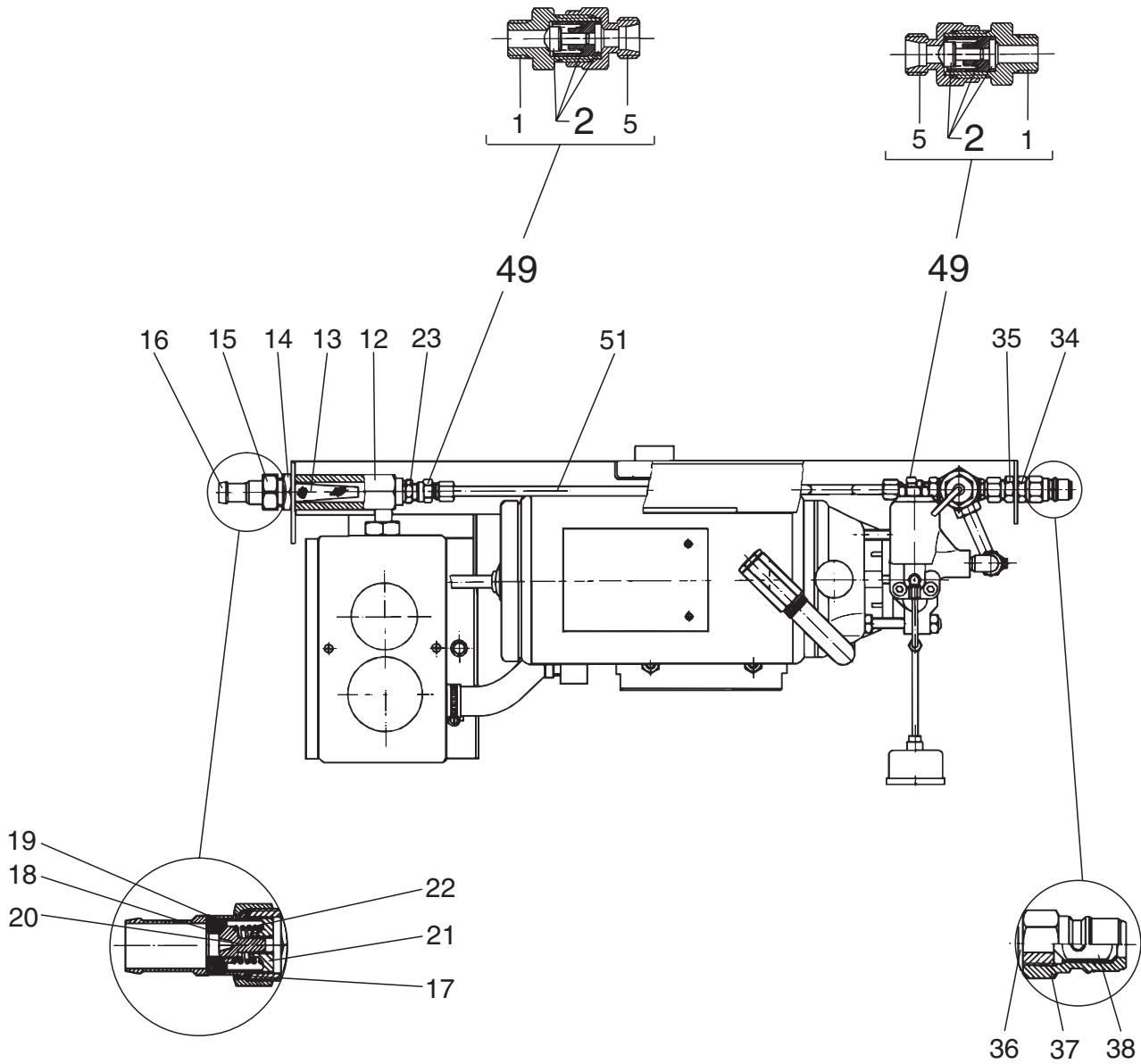

Filterhus, kompl. / Filter housing, compl. / Gehäuse f. Filter, kompl. / Carter filtre, compl.

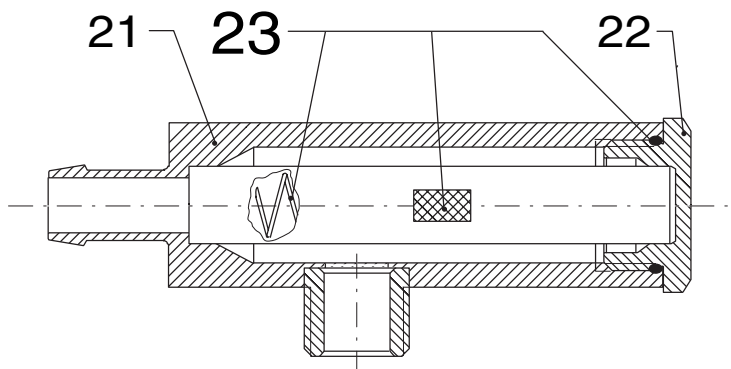

Pos. Ref.	Nr. No.	Betegnels Bezeichnung	Designation Désignation	17A2KSA	40A2KSA
42	1801174	Skrue Screw Schraube Vis		4	4
43	1803725	Møtrik Nut Mutter Ecrou		6	6
44	1801398	Skive Washer Scheibe Rondelle		8	8
46	3800760	Trækafastning Cable lead-in Kabeldurchführung Isolateur de traversée		1	1
47	6350456	Udluftningsskrue Venting screw Entlüftungsschraube Vis de purge		1	1
49	-	Kontraventil, venstre Non return valve, left Rückschlagventil, links Clapet anti-retour, gauche		1	1
51	6350459	Rør Tube Rohr Tube		1	1
52	1803725	Møtrik Nut Mutter Ecrou		2	2
53	1800622	Skrue Screw Schraube Vis		1	1
54	6352256	Motorplade Bracket f. motor Stützplatte f. Motor Support moteur		1	1
55	1800762	Skrue Screw Schraube Vis		2	2
56	1804095	Skive Washer Scheibe Rondelle		4	4
57	1801968	Skive Washer Scheibe Rondelle		4	4
58	1800465	Møtrik Nut Mutter Ecrou		2	2
59	1803337	Skrue Screw Schraube Vis		2	2

Pos. Ref.	Nr. No.	Betegnels Bezeichnung	Designation Désignation	17A2KSA	40A2KSA
49	-	Kontraventil, venstre Non return valve, left Rückschlagventil, links Clapet anti-retour, gauche		1	1
1	6350352	Studs Socket Stutzen Raccord		1	1
2	1119566	Rep. sæt, kontraventil Rep. kit, non return valve Rep. satz, Rückschlagventil Kit de rép., clapet anti-retour			
5	6350353	Møtrik Nut Mutter Ecrou		1	1
-	6105388	Filterhus, kompl. Filter housing, compl. Gehäuse f. Filter, kompl. Carter filtre, compl.		x	x
21	6105625	Filterhus Filter housing Gehäuse f. Filter Carter filtre		1	1
22	6105545	Prop Plug Pfropfen Bouchon		1	1
23	1119316	Rep. sæt, filterhus Rep. kit, filter housing Rep. satz, Gehäuse f. Filter Kit de rép., carter filtre		1	1

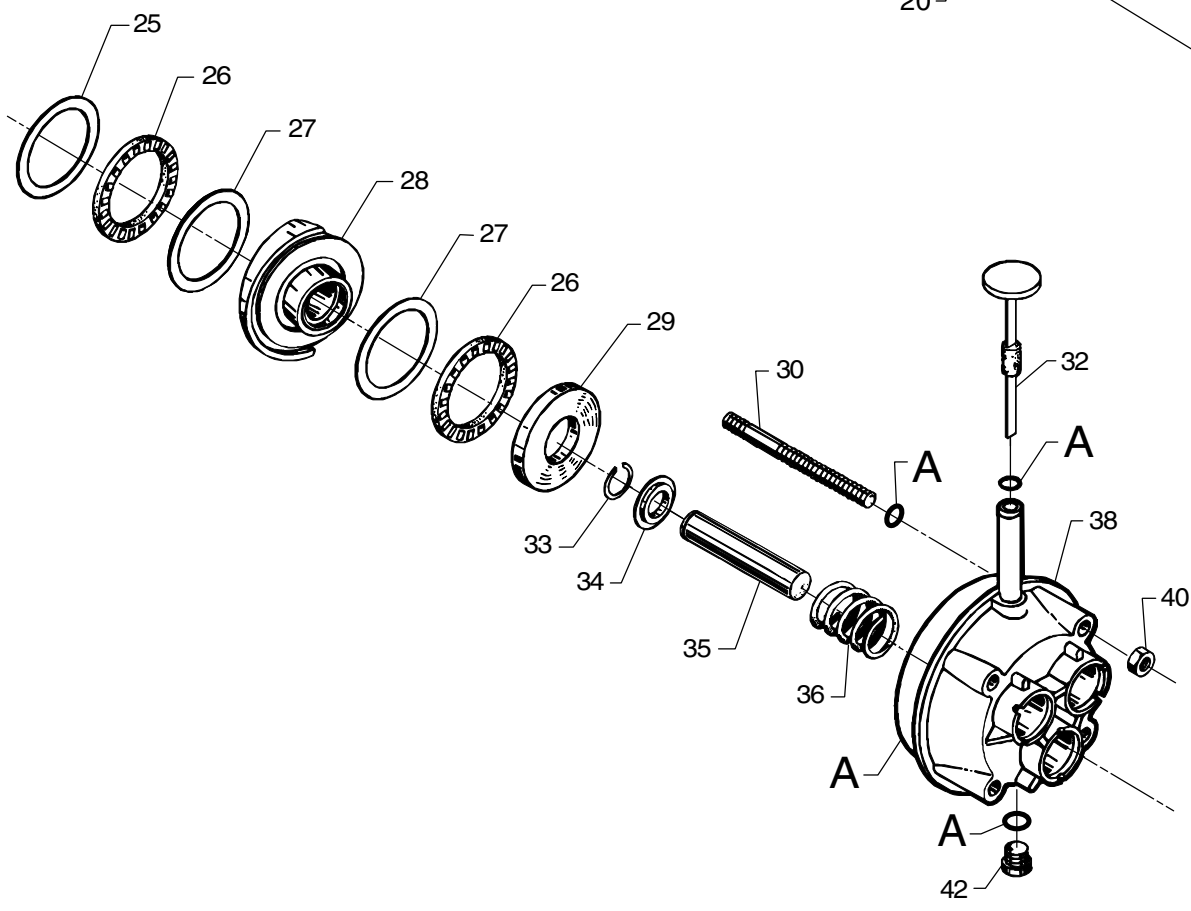
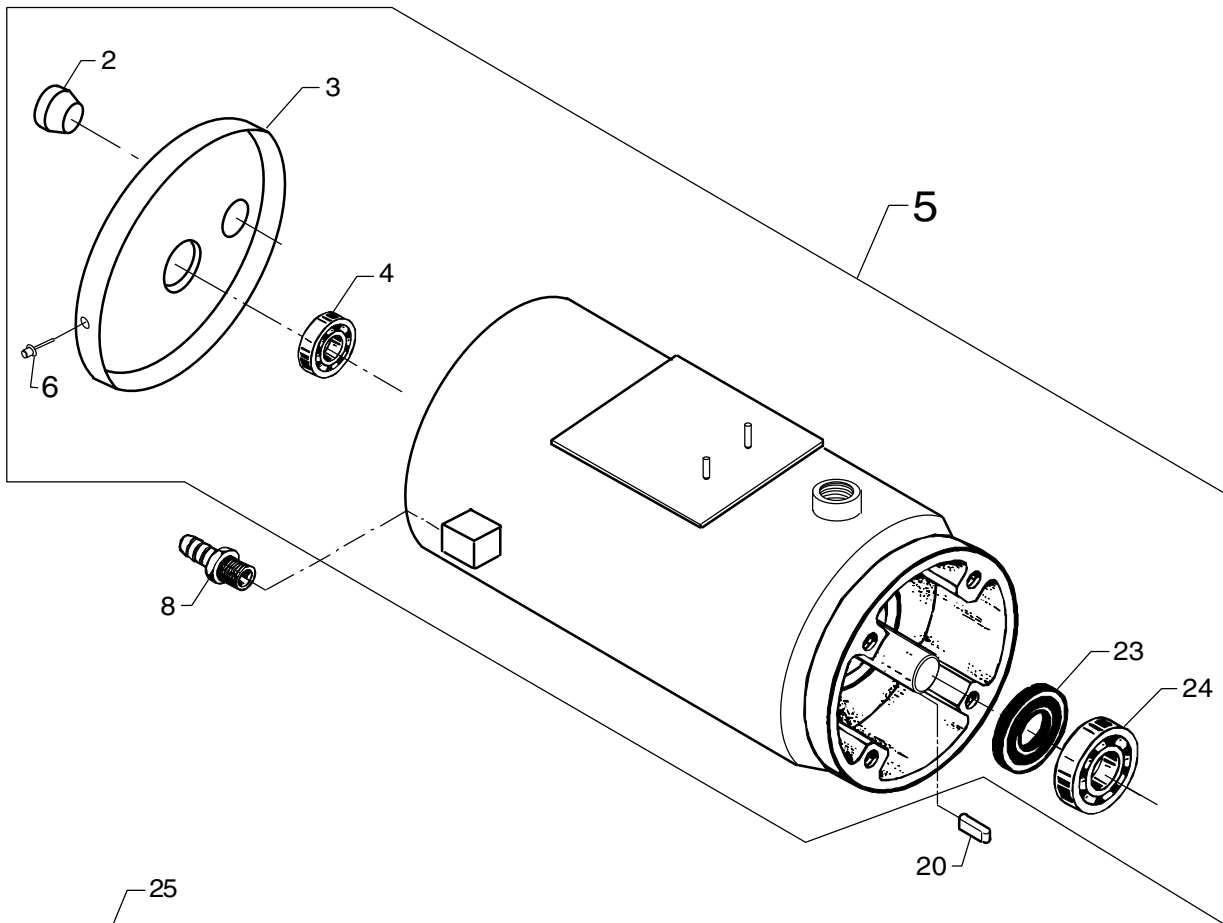

Pos. Ref.	Nr. No.	Betegnelse Bezeichnung	Designation Désignation	17A2KSA	40A2KSA
1	-	Motorpumpeenhed, komp. Motor/pump unit, compl. Motorpumpeneinheit, kompl. Corps de moteur/pompe, compl.		x	x
2	3803780	Pakdåse Cable grommet Stopfbuchse Presse-étoupe	TET 10 - 14C	1	1
3	6105485	N-lejedæksel Rear bearing cover N-Lagerdeckel AR-flasque de carter		1	1
4	3200870	Kugleleje Ball bearing Kugellager Roulement à bille		1	1
5	-	Motor, komplet Motor, complete Motor, komplett Moteur, compl.			
-	6105330	3x220V/3x380V, 50Hz		1	
-	6105334	3x250V/430V		1	
-	6105335	3x220V/346V		1	
-	6105332	1x240V, 50Hz		1	
6	1813260	Popnitte Rivet Niet Rivet		2	2
8	6300262	Slangestuds Socket f. hose Schlauchstutzen Raccord p. flexible		1	1
20	3200789	Feder Key Federkeil Clavette		1	1
23	3001872	Olietætningsring Oil gasket Öldichtungsring Joint d'huile		1	1
24	3200888	Kugleleje Ball bearing Kugellager Roulement à bille		1	1
25	3200896	Lejering Bearing ring Ring f. Lager Rondelle		1	1
26	3200912	Nåleleje Needle bearing Nadellager Roulement à aiguille		2	2
27	3200904	Lejering Bearing ring Ring f. Lager Rondelle		2	2
28	-	Skråskive Wobble disc Taumelscheibe Disque oblique			
-	6105504	B		1	
-	6105505	C			1
-	6105506	D			1
29	6105499	Lejeskive Bearing track Lagerscheibe Rondelle de palier		1	1
30	6105480	Stagbolt L=130mm Stay bolt Stehbolzen Entretoise		4	4
32	6105375	Oliepind Oil gauge pin Ölmeßstab Orifice de remplissage d'huile		1	1

Pos. Ref.	Nr. No.	Betegnelse Bezeichnung	Designation Désignation	17A2KSA	40A2KSA
33	1803162	Låsering Circlip Schließring Anneau		3	3
34	6105521	Ring til returfeder Ring for return spring Ring für Rückzugfeder Anneau p. ressort de rap.		3	3
35	6152604	Stempel Piston Druckkolben Piston			3
35	6150619	Stempel Piston Druckkolben Piston		3	
36	2600591	Returfeder Return spring Rückzugfeder Ressort de rappel		3	3
38	6105474	Cylinderblok Cylinder block Zylinderblock Carter-cylindre		1	1
40	1800465	Motrik Nut Mutter Ecrou		6	6
42	6105533	Olieaftapningsprop Oil drain plug Ölablaßpfropfen Bouchon de vidange huile		1	1

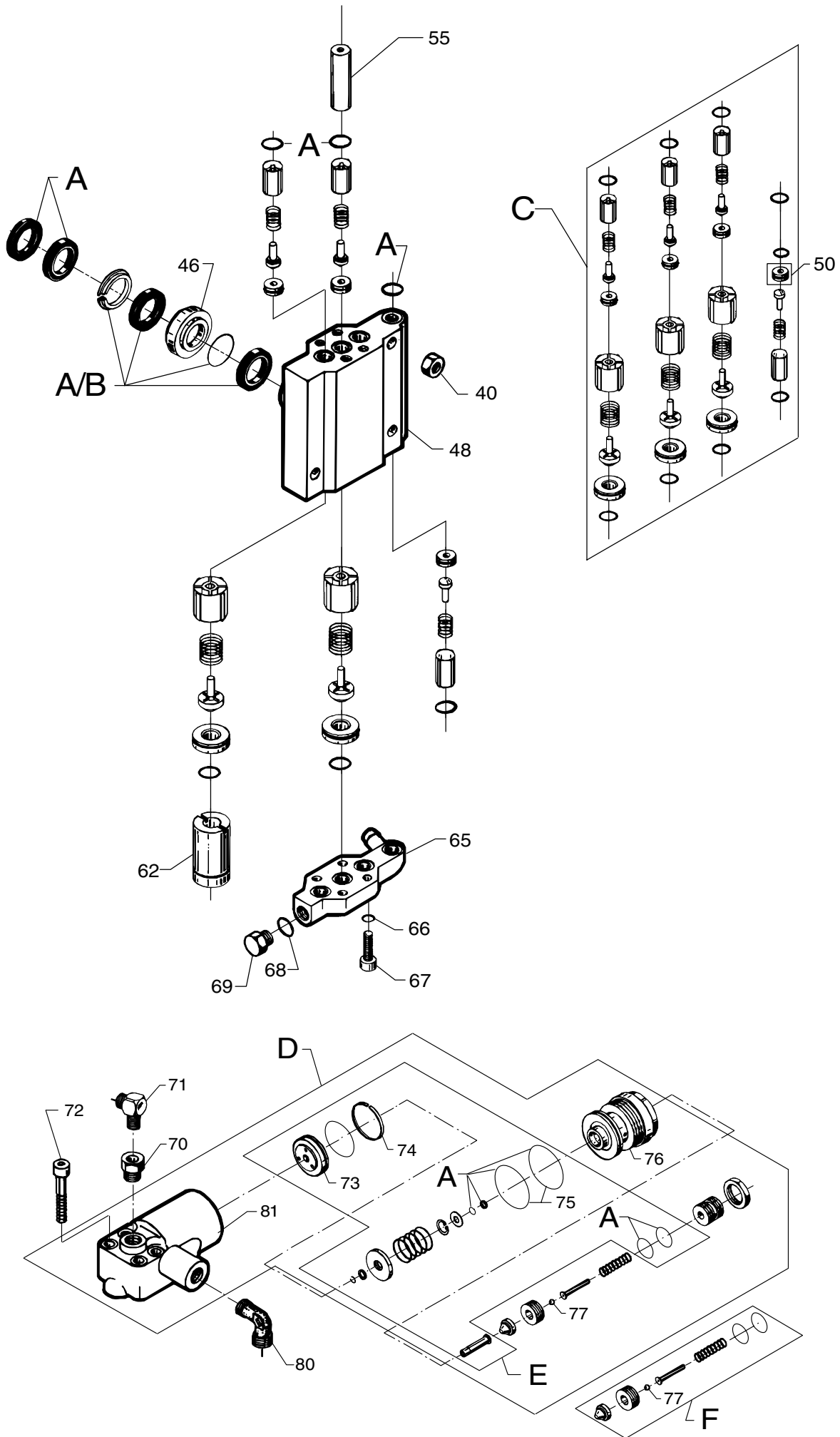

Pos. Ref.	Nr. No.	Betegnelsen Bezeichnung	Designation Désignation	17A2KSA	40A2KSA
A	1119017	Rep.sæt, pakninger Rep.kit, gaskets Rep.satz, Dichtungen Kit de joints		1	1
B	1119037	Rep.sæt, pakninger (red.) Rep.kit, gaskets (red.) Rep.satz, Dichtungen (red.) Kit de joints (réduit)		1	1
46	6150609	Trykring Thrust collar Druckring Anneau d'arrêt		3	3
48	6105476	Topstykke Cylinder head Zylinderkopf Culasse		1	1
C	1119310	Rep.sæt, ventilsystem Rep.kit, valvesystem Rep.satz, Ventilsystem Kit de système de clapet		1	1
50	6402307	Ventilsæde Valve seat Ventilsitz Siège du clapet	⇒ 09.08.95		1
-	6350503	Ventilsæde Valve seat Ventilsitz Siège du clapet	09.08.95 ⇒		1
-	6200568	Ventilsæde Valve seat Ventilsitz Siège du clapet		1	
55	6150611	Afstandsstykke Spacer Zwischenstück Pièce d'espace		1	1
62	6105500	Afstandsstykke Spacer Zwischenstück Pièce d'espace		2	2
65	6105482	Indsugningsdæksel Suction cover Einlaßdeckel Couvercle d'aspiration		1	1
66	1801182	Skive Washer Scheibe Rondelle		4	4
67	1803337	Sætskrue Set screw Gewindestift Vis de blocage		4	4
68	3000460	O-ring O-ring O-Ring Joint torique		1	1
69	6105533	Prop Plug Pfropfen Bouchon		1	1
70	1601046	Nippelmuffe Sleeve f. nipple Muffe f. Nippel Bouchon p. entrée raccord		1	1
71	1604826	Vinkelforskrunding Threaded connection, elbow Verschraubung Raccord fileté, coudé		1	1
72	1804590	Skrue Screw Schraube Vis		4	4
73	6105523	Ventilstempel Valve piston Ventilkolben Piston (de la soupape)		1	1
74	6150693	Stempelring Ring f. piston Ring f. Kolben Anneau piston		1	1

Pos. Ref.	Nr. No.	Betegnelsen Bezeichnung	Designation Désignation	17A2KSA	40A2KSA
75	3001385	O-ring O-ring O-Ring Joint torique		1	1
76	6150642	Bundskrue Screw Schraube Vis		1	1
77	1600311	Kugle Ball Kugel Bille		1	1
D	6350528	Omløbsventil, kompl. By-pass valve, compl. Umiaufventil, kompl. Soupape by-pass, compl.		1	1
E	1119013	Rep.sæt, omløbsventil Rep.kit, by-pass valve Rep.satz, Umiaufventil Kit de soupape by-pass		1	1
F	1119038	Rep.sæt, sikkerhedsventil Rep.kit, safety valve Rep.satz, Sicherheitsventil Kit de soupape de sûreté		1	1
80	1603119	Vinkel Elbow Winkel Coudé		1	1
81	6105528	Ventildæksel Valve cover Ventildeckel Corp by-pass		1	1

Strømningskontakt / Flow switch / Strömungsschalter / Circulation sélecteur

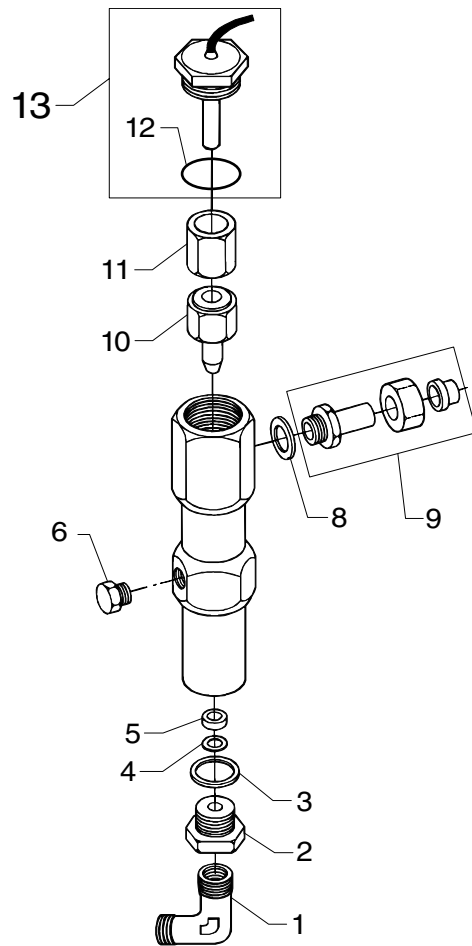

Svømmerhus / Water tank / Schwimmergehäuse / Bac à flotteur

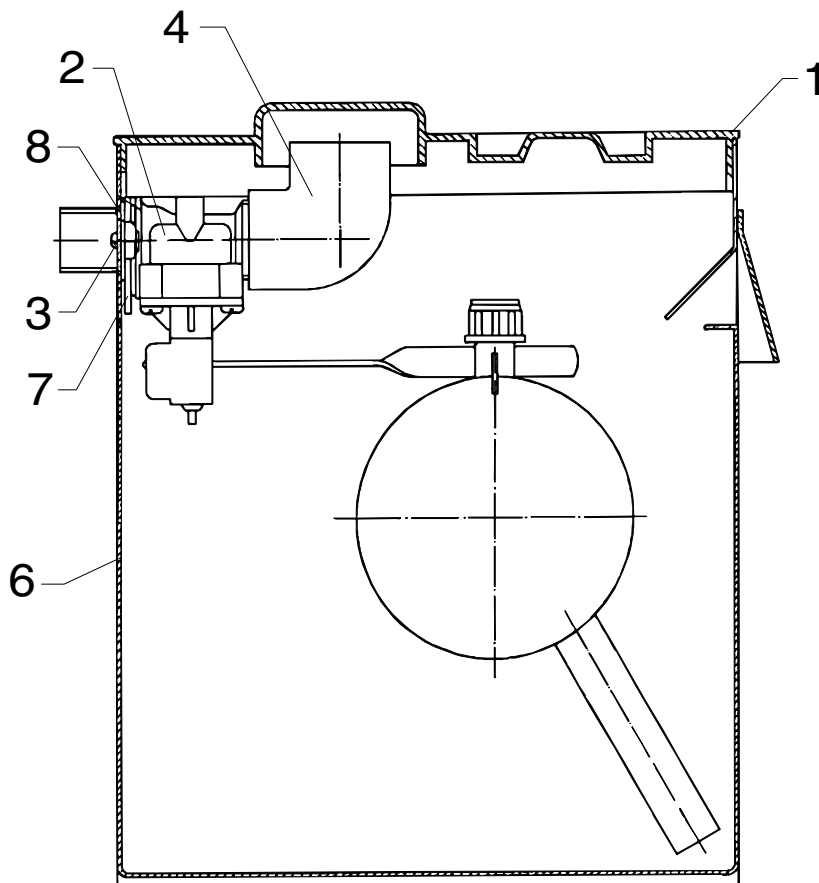

Pos. Ref.	Nr. No.	Betegnels Bezeichnung	Designation Désignation	17A2KSA	40A2KSA
42	6350455	Strømningskontakt, komplet Flow switch, complete Strömungsschalter, komplett Circulation sélecteur, compl.		x	x
1	1603119	Vinkel Elbow Winkel Coude		1	1
2	6300438	Omløber Union nut Überwurfmutter Ecrou-raccord		1	1
3	3000262	O-ring O-ring O-Ring Joint torique		1	1
4	3001641	O-ring O-ring O-Ring Joint torique		1	1
5	6350625	Sæde Seat Sitz Siège		1	1
6	6200529	Prop Plug Pfropfen Bouchon		1	1
8	1803493	Tætningsskive Sealing washer Dichtungsscheibe Rondelle d'étanchéité		1	1
9	6350527	Forskrning Threaded connection Verschraubung Raccord fileté		1	1
10	6350463	Stempel, kompl. Piston, compl. Kolben, kompl. Piston, compl.		1	1
11	6350454	Stempel, kompl. Piston, compl. Kolben, kompl. Piston, compl.		1	1
12	3000825	O-ring O-ring O-Ring Joint torique		1	1
13	6221773	Reedkontakt m. O-ring Reed switch with O-ring Reedschalter mit O-ring Reed sélecteur avec joint torique		1	1
-	1602325	Prop Plug Pfropfen Bouchon	11.09.92 =>	1	1

Pos. Ref.	Nr. No.	Betegnels Bezeichnung	Designation Désignation	17A2KSA	40A2KSA
-	6350465	Svømmerhus, kompl. Water tank, compl. Schwimmergehäuse, kompl. Bac à flotteur, compl.		x	x
1	6352107	Låg Cover Deckel Couvercle		1	1
1	6350371	Låg Cover Deckel Couvercle	=> 22.06.88	1	1
2	1117035	Svømmerventil Float valve Schwimmerventil Clapet anti-retour		1	1
3	1802891	Skrue Screw Schraube Vis		2	2
4	1605971	Vinkel Elbow 3/4" Winkel Raccord coudé		1	1
5	1805860	Skrue Screw Schraube Vis	=> 22.06.88	6	6
6	6200626	Svømmerhus Waater tank Schwimmergehäuse Bac à flotteur		1	1
-	6350464	Svømmerhus Water tank Schwimmergehäuse Bac à flotteur	=> 22.06.88	1	1
7	3001724	Pakning Gasket Dichtung Joint		1	1
8	3001435	Pakning Gasket Dichtung Joint		1	1
-	6350375	Pakning f. låg Gasket f. cover Dichtung f. Deckel Joint p. couvercle	=> 22.06.88	1	1

Eldele / Electrical components / Elektrische Komponenten / Eléments électriques

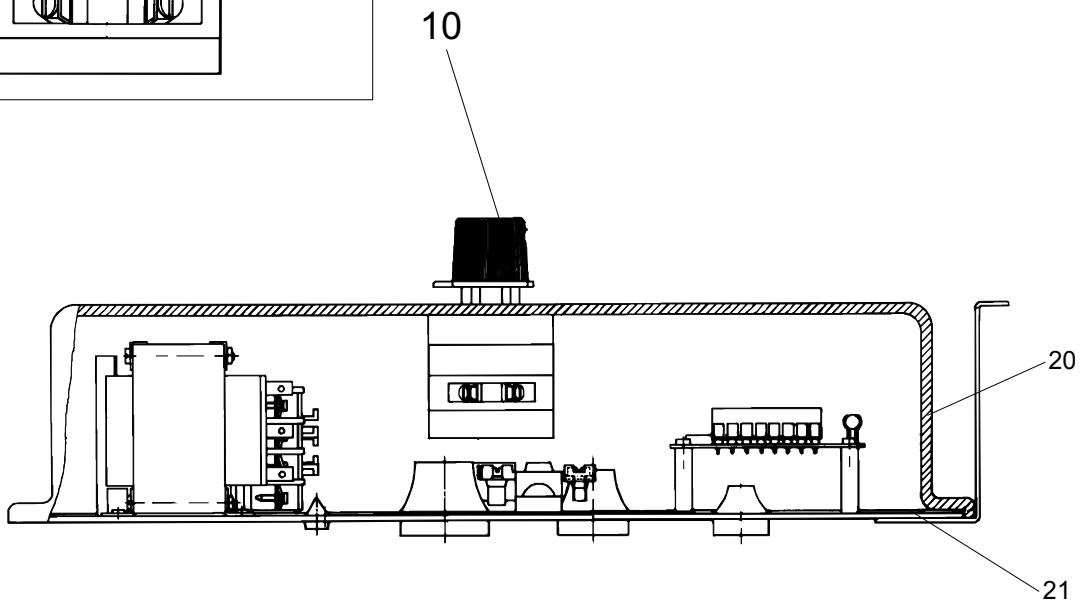
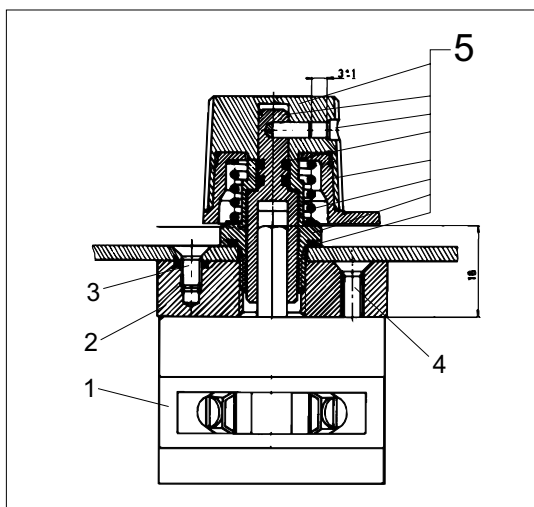
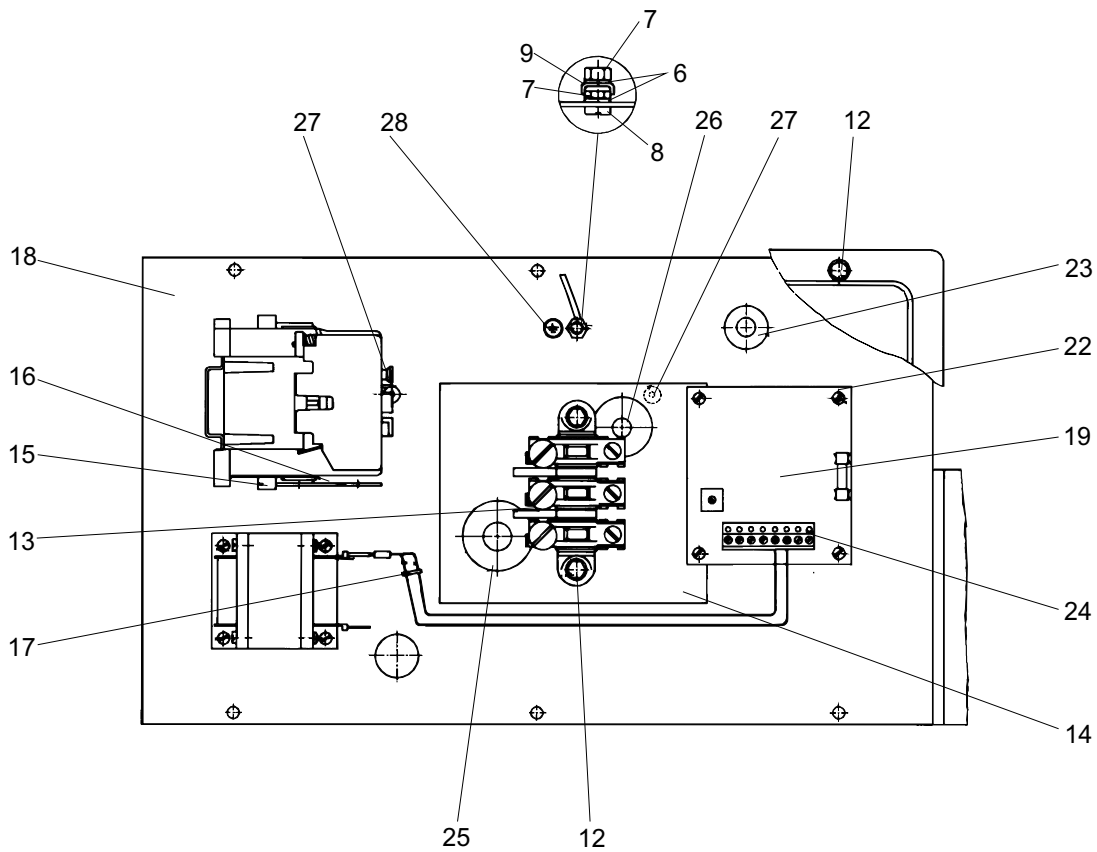

52Sel000

Pos. Ref.	Nr. No.	Betegnelse Bezeichnung	Designation Désignation	17A2KSA	40A2KSA
-	-	Eldele Electrical components Elektrische Komponenten Éléments électriques		x	x
1	3804895	Start/stop kontakt Start/stop switch Start/Stopp Schalter Bouton de commande		1	1
2	6101588	Mellemstykke Spacer Zwischenstück Pièce d'espace		1	1
3	1803451	Skrue Screw Schraube Vis		1	1
4	1802685	Skrue Screw Schraube Vis		1	1
5	1117357	Drejeknapp rød, kompl. Adjusting knob red, compl. Drehschalter rot, kompl. Interrupteur à rotation rouge, compl.		x	x
6	1802727	Skive Washer Scheibe Rondelle		2	2
7	1802743	Møtrik Nut Mutter Ecrou		2	2
8	1802859	Skrue Screw Schraube Vis		1	1
9	1802735	Klembøjle Clamp Bügel Support			1
10	3805991	Start/stop kontakt, kompl. Start/stop switch, compl Start/Stopp Schalter, kompl. Bouton de commande, compl.		x	x
12	1803956	Skrue Screw Schraube Vis		8	8
13	3803822	Rækkelemme Terminal screw Anschlußklemme Borne		1	1
14	6151968	Underlag f. rækkelemme Support f. terminal screw Unterlag f. Anschlußklemme Support p. borne		1	1
15	6155912	Underlag f. kontaktor Support f. contactor Unterlag f. Schütz Support p. contacteur		1	1
16	6100101	Ledningsholder Cable clip Kabelhalter Support de câbles		1	1
17	1803329	Kabelbinder Clamp f. cable Kabelhalter Collier de serrage pour câble		4	4
18	6350250	Instrumentplade Control panel Armaturen Brett Tableau de commande		1	1
19	6350550	Print Circuit board Print Circuit imprimé		1	1
20	6350114	Instrumentkasse Control panel Armaturen Brett Boîtier électrique		1	1

Pos. Ref.	Nr. No.	Betegnelse Bezeichnung	Designation Désignation	17A2KSA	40A2KSA
21	6350626	Pakning Gasket Dichtung Joint		1	1
22	1803139	Skrue Screw Schraube Vis		4	4
23	3803764	Gummipakdåse Cable grommet Stopfbuchse Presse-étoupe	TET 5-7 C	2	2
24	3805439	Stik Plug Stecker Prise		1	1
25	3803798	Gummipakdåse Cable grommet Stopfbuchse Presse-étoupe	TET 14-20 C	1	1
26	3803780	Gummipakdåse Cable grommet Stopfbuchse Presse-étoupe	TET 10-14 C	1	1
27	4600672	Blændprop Plug Verschluß Bouchon		2	2
28	3800059	Jordtegn Earth symbol Symbol, Erdung Symbole-terre		1	1

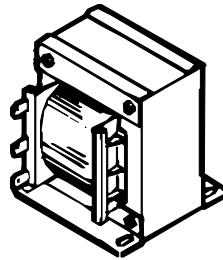
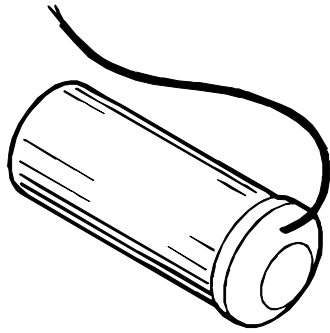
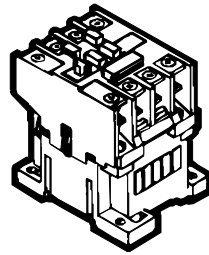
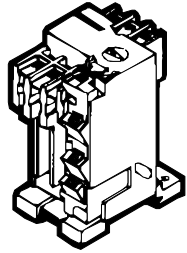

Pos. Ref.	Nr. No.	Betegnelse Bezeichnung	Designation Désignation	17A2KSA	40A2KSA
30	-	Termorelæ Thermal relay Thermorelais Relais thermique		1	1
-	3811627	CT3-12	⇒ 31.12.99		
-	3821737	193-EA4FB	01.01.00 ⇒		
-	3806551	CT 12-17,5A	⇒ 31.12.99		
-	3821736	193-EA4GB	01.01.00 ⇒		
31	-	Kontaktor Contactor Schütz Contacteur		1	1
-	3821404	CA3-16-10	⇒ 31.12.99		
-	63903	16A 24V 50-60Hz	01.01.00 ⇒		
-	3804168	CA3-23-10	⇒ 31.12.99		
-	63907	23A 24V 50-60Hz	01.01.00 ⇒		
32	3804978	Kondensator Capacitor 66 µf Kondensator Condensateur		1	
-	6151958	Kondensatorholder Fitting f. capacitor Halter f. Kondensator Support p. condensateur		1	
33	-	Transformer Transformer, 24-2A Transformator Transformateur			
-	3804762	380V, 50/60Hz		1	
-	3804788	415-440V, 50/60Hz		1	
-	3804770	220V, 50/60Hz		1	1
-	3804796	200V, 60Hz		1	

Pos. Ref.	Nr. No.	Betegnelse Bezeichnung	Designation Désignation	17A2KSA	40A2KSA
-	-	Tilgangskabel Electric cable Anschlußkabel Câble électrique		1	1
	6350610	H05VV-F 3G 1,5			
	6350611	H05VV-F 4G 1,5			
	6350616	H07RN-F 4G 1,5			
	6350619	H07RN-F 4G 1,5			
	6350612	H05VV-F 4G 2,5			
-	-	Stik Plug Stecker Prise		1	1
	3802493	CEE 5 pol. 380V/16A			
	3802477	S			