

40C 40CA

⇒ 01.04.95 |

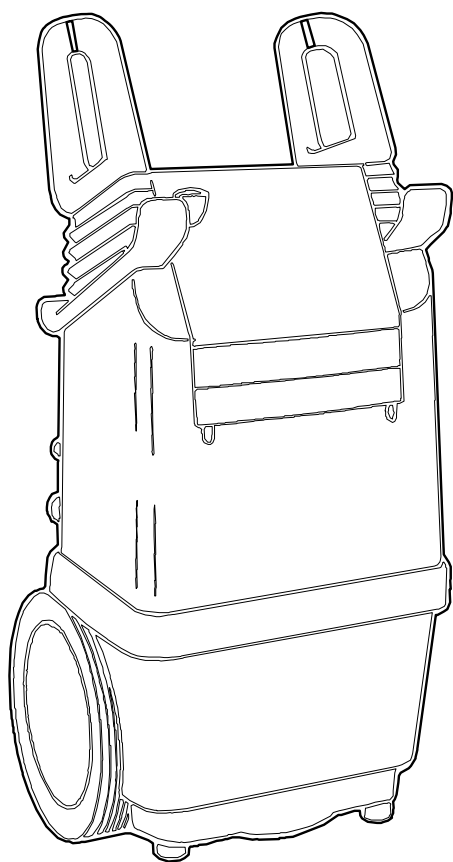

ALTO®

Total Cleaning
Confidence™

Reserve de le
Spare parts
Ersatzteile
Pièces détachées

598 51 40 - 00.07

2 INDEX
1

KEW
TECHNOLOGY

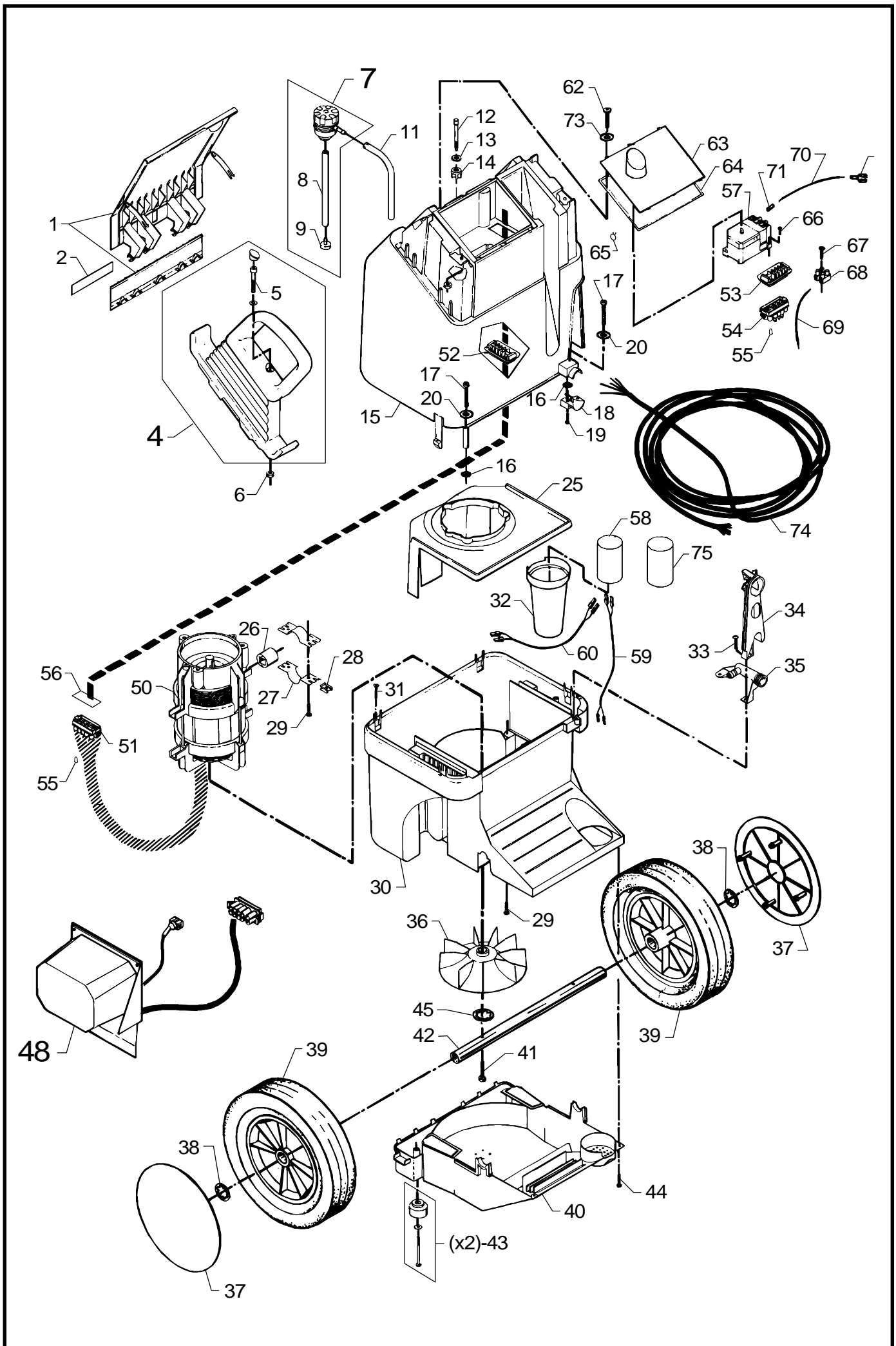

Pos. Ref.	Nr. No.	Betegnelse Bezeichnung	Designation Désignation	0940C	15-1740CA	2040C/CA	3340C/CA	4040CA
1	6180423	Dunkholder Container rack Behältergestell Capot receptacle		1	1	1	1	1
2	-	Logo, ALTO Logo Logo Logo						
-	4209556	0940C		1				
-	4209553	1740C			1			
-	4209554	2040C				1		
-	4209555	3340C					1	
-	4209557	1740CA			1			
-	4209558	2040CA				1		
-	4209552	2540CA						
-	4209559	3340CA					1	
-	4209560	4040CA						1
4	1119211	Rep.sæt, kørehåndtag H+V Rep.kit, steering handle L+R Rep.satz, Handbügel R+L Kit de rép., poignée de g. D+G		x	x	x	x	x
5	1813385	Skrue Screw, Insex Schraube Vis	M 8x60	2	2	2	2	2
6	6184920	Møtrik Nut Mutter Écrou		2	2	2	2	2
7	6180410	Doseringsenhed, kompl. Dosing unit, compl. Dosierungseinheit, kompl. Unité de injecteur, compl.		x	x	x	x	x
8	2450002	Slange Hose Schlauch Tuyau	300mm	1	1	1	1	1
9	6400240	Filter Filter Filter Filtre		1	1	1	1	1
11	2450001	Slange Hose Schlauch Tuyau	1510mm	1	1	1	1	1
12	6181535	Bolt f. kabinet Bolt f. Cabinet Bolzen f. Gehäuse Boulon p. capot		1	1	1	1	1
13	1802917	Skive Washer Scheibe Rondelle		1	1	1	1	1
14	6180718	Gummi tulle Rubber bush Gummi tülle Douille p. câble, caoutch.		1	1	1	1	1
15	6180732	Kabinet top, ALTO Top cabinet Oberteil des Gehäuses Capot supérieur		1	1	1	1	1
-	6180753	Kabinet top ALTO Top cabinet Oberteil des Gehäuses Capot supérieur	UNITOR	1	1	1	1	1
16	3004199	O-ring O-ring O-Ring Joint torique	ø 3x1	4	4	4	4	4
17	1813948	Skrue Screw Schraube Vis	M 3,5x30	2	2	2	2	2
18	6180722	Kabelafastning Cable lead-in Zugentlastung Sene colle		1	1	1	1	1

Pos. Ref.	Nr. No.	Betegnelse Bezeichnung	Designation Désignation	0940C	15-1740CA	2040C/CA	3340C/CA	4040CA
18	6180728	Kabelafastning Cable lead-in Zugentlastung Sene colle	CDN				1	1
19	1813930	Skrue Screw Schraube Vis	M 3.5x25	2	2	2	2	2
20	1813922	Skive Washer Scheibe Rondelle	ø4xø9	2	2	2	2	2
25	6180705	Vandskjold Water shield Wasserschild Bouclier d'eau		1	1	1	1	1
26	6184675	Gummiophæng Rubber motor mounting Gummiaufhängung Amortisseur caoutchouc		4	4	4	4	4
27	6180717	Bøjlebeslag Fitting Beschlag Garniture		4	4	4	4	4
28	1813708	Plade clips Sheet metal clip Blechklammer Clip p. plaque		4	4	4	4	4
29	1813542	Pladeskrue Sheet metal screw Blechschrabe Vis à tôle	B10x25	4	4	4	4	4
30	6180700	Kabinet bund Bottom cabinet Unterteil des Gehäuses Dessous du capot		1	1	1	1	1
31	6180724	Låsestift Lock pin Paßstift Goupille		4	4	4	4	4
32	6180704	Kondensatorholder Capacitor holder Kondensatorhalter Condensateur sup.		2	2	2		
33	1805340	Pt-skrue Pt-screw Pt-Schraube Vis	M5x20	3	3	3	3	3
34	6180715	Manometer dæksel Pressure gauge cover Manometerdeckel Couvercle de manometre		1	1	1	1	1
35	6180617	Filterhus Housing f. filter Filtergehäuse Gaine de filtre d'eau		1	1	1	1	1
36	1119643	Rep. sæt for ventilator Rep. kit for fan Rep. satz für Ventilator Kit de rép. pour ventilateur		1	1	1	1	1
37	6184136	Navkapsel, ALTO Hub cap Radkappe Chapeau de roue		2	2	2	2	2
38	1813799	Låseskive Lock washer Federtellerscheibe Circlip		2	2	2	2	2

Pos. Ref.	Nr. No.	Betegnelse Bezeichnung	Designation Désignation	0940C	15-1740C/CA	2040C/CA	3340C/CA	4040CA
39	6184074	Kørehjul Wheel Rad Roue		2	2	2	2	2
40	6180706	Bunddæksel Bottom cover Unterteil des deckel Couvercle dessus		1	1	1	1	1
41	1813427	Pt-skrue Pt-screw Pt-Schraube Vis	5x42	2	2	2	2	2
42	6180720	Aksel Axle Achse Axe roue		1	1	1	1	1
43	6180901	Gummifod 2 stk., kompl. Rubber foot 2 pcs., compl. Gummifuß 2 stück, Kompl. Pied de caoutcho. 2 pièces		1	1	1	1	1
44	1813419	Pt-skrue Pt-screw 5x15 Pt-Schraube Vis		2	2	2	2	2
45	1814102	Skive Washer Scheibe Rondelle		1	1	1	1	1
48	-	El-kasse Connection box Electrogehäuse Boîtier électrique		Se side 13 See page 13 Siehe Seite 13 Voir page 13				
50	-	El-motor El-motor Electromotor Moteur		Se side 7 See page 7 Siehe Seite 7 Voir page 7				
51	3820230	Motorstik (hun) Motor plug (female) Motorstecker (innen) Fiche moteur (femelle)						
52	-	Motorstik (han) Motor plug (male) Motorstecker (außen) Fiche moteur (mâle)						
-	3820214	Stjernekobling Star connection Sternschaltung Étoile-commutation	Y					
-	3820206	Trekants-kobl. Delta connection Dreieckschalter Triangle-commutation	Δ					
53	3820222	Omkoblingsstik (han) Change-over plug (male) Umschaltstecker (außen) Fiche de commutation (mâle)						
54	-	Omkoblingsstik (hun) Change-over plug (female) Umschaltstecker (innen) Fiche de commutation (femelle)						
-	3820537	Y stjernekobling Star connection Sternschalter Étoile-commutation	Y					
-	3820529	Trekants-kobl. Delta connection Dreieckschalter Triangle-commutation	Δ					
55	3820909	Blændprop Plug Pfropfen Bouchon		3	3	3	3	3
56	3821456	Pakning for motorstik Gasket f. motor plug Dichtung f. Motorstecker Joint p. Fiche de commutation		1	1	1	1	1

Pos. Ref.	Nr. No.	Betegnelse Bezeichnung	Designation Désignation	0940C	15-1740C/CA	2040C/CA	3340C/CA	4040CA
57	-	Maximalafbryder Overload cut-out x5 Motorschutzschalter Interrupteur maximale		1	1	1	1	1
-	3820156	OKA 10						
-	3820164	OKA 16						
-	3820172	OKA 22						
-	3820180	OKA 30						
58	3821427	Kondensator (drift) Capacitor (operation) Kondensator (Betrieb) 220-240V Condensateur (fonction.)	40 µF					
58	3821426	Kondensator (drift) Capacitor (operation) Kondensator (Betrieb) 110-115V Condensateur (fonction.)	100 µF					
59	6180270	Kondensatorledning (drift) Capacitor cable, (oper.) Kondensatorleitung (Betrieb) Câble de condensateur (fonction.)	CDN					
59	6180271	Kondensatorledning (drift) Capacitor cable (oper.) Kondensatorleitung (Betrieb) Câble de condensateur (fonction.)						
60	6180272	Kondensatorledning (start) Capacitor cable (start-up) Kondensatorleitung (Start) Câble de condensateur (marche)						
60	6180277	Kondensatorledning (start) Capacitor cable, (start-up) Kondensatorleitung (Start) Câble de condensateur (marche)	CDN					
62	1813955	Skrue Screw Schraube Vis	M 3x10	3	3	3	3	3
63	-	Instrument panel pos. (63+65), ALTO Control panel ref. (63+65) Armaturenbrett pos. (63+65) Tableau de commande ref. (63+65)						
-	6180955	0940C		1	(1)			
-	6180956	1540C			1			
-	6180952	1740C				1		
-	6180953	2040C						
-	6180954	3340C					1	
-	6180957	1740CA			1			
-	6180958	2040CA				1		
-	6180950	2540CA					1	
-	6180959	3340CA						1
-	6180960	4040CA						1
64	6180723	Pakning Gasket Dichtung Joint		1	1	1	1	1
65	1814078	Låseklemme Clip Klemme Pince de serrure		1	1	1	1	1
66	1813443	Pt-skrue Pt-screw 3x16 Pt-Schraube Vis		2	2	2	2	2
68	3807872	Samlemuffe, jord Connecting sleeve, earth Anschlußmuffe, Erdung Manchon de raccordement, terre		1	1	1	1	1
69	-	Ledning, jord gul/grøn Cable, earth yellow/green Leitung, Erdung Gelb/Grün Câble, terre jaune/vert	1x2,5 / H07V-K	x	x	x	x	x
70	-	Ledning, sort Cable, black Leitung, Schwarz Câble, noir	1x2,5 / H07V-K	x	x	x	x	x
-	-	Ledning Cable Leitung Câble	TEW 105°C AWG 18 USA	x	x	x	x	x

598 51 40 - 00.07

Pos. Ref.	Nr. No.	Betegnelse Bezeichnung	Designation Désignation					
				0940C	15-1740CA	2040C/CA	3340C/CA	4040CA
72	3820941	Kabelsko Thimble of cable Kabelschuh Cousse de câble		x	x	x	x	x
73	1813914	Skive Washer ø3xø7 Scheibe Rondelle		3	3	3	3	3
74	-	El-kabel El.cable Anschlußkabel Câble électrique		Se side 7 See page 7 Siehe Seite 7 Voir page 7				
75	3821063	Kondensator, (start) 160 - 200 µF Capacitor (start-up) 04.01.93 ⇒ Kondensator (Start) 220-240V Condensateur (marche)						
75	3821139	Kondensator (start) 200-250 µF Capacitor (start-up) ⇒ 04.01.93 Kondensator (Start) 220-240V Condensateur (marche)						
75	3821216	Kondensator (start) 315 - 350 µF Capacitor (start-up) Kondensator (Start) 110-115V Condensateur (marche)						
-	3800059	Jordtegn Earth symbol Erddungszeichen Symbol - terre	1	1	1	1	1	1
50	-	El-motor m. feder El. motor w. Key 50 (60) Hz El-motor m. Federkeil El. moteur a. clavette						
-	6183379	1x220 -230V, 50 Hz		1				
-	6183377	1x240 V, 50 Hz		1				
-	6183376	3x380V, 50Hz 3x380/220 V, 50 Hz			1			
-	6183375	3x380/220 V, 3x380 V,50 Hz 3x440/220 V, 60 Hz 3x415-440 V, 60 Hz 3x220 V, 60 Hz				1		
-	6183374	3x400 V, 50 Hz 3x440/220 V, 60 Hz 3x415-440 V, 60 Hz					1	
-	6183373	3x346/200 V, 50/60 Hz	J					1
-	6183372	3x415-440 V, 50 Hz						1
-	6183378	3x415-440 V, 50 Hz				1		
-	6183384	1x110 V, 50Hz	GB	1				

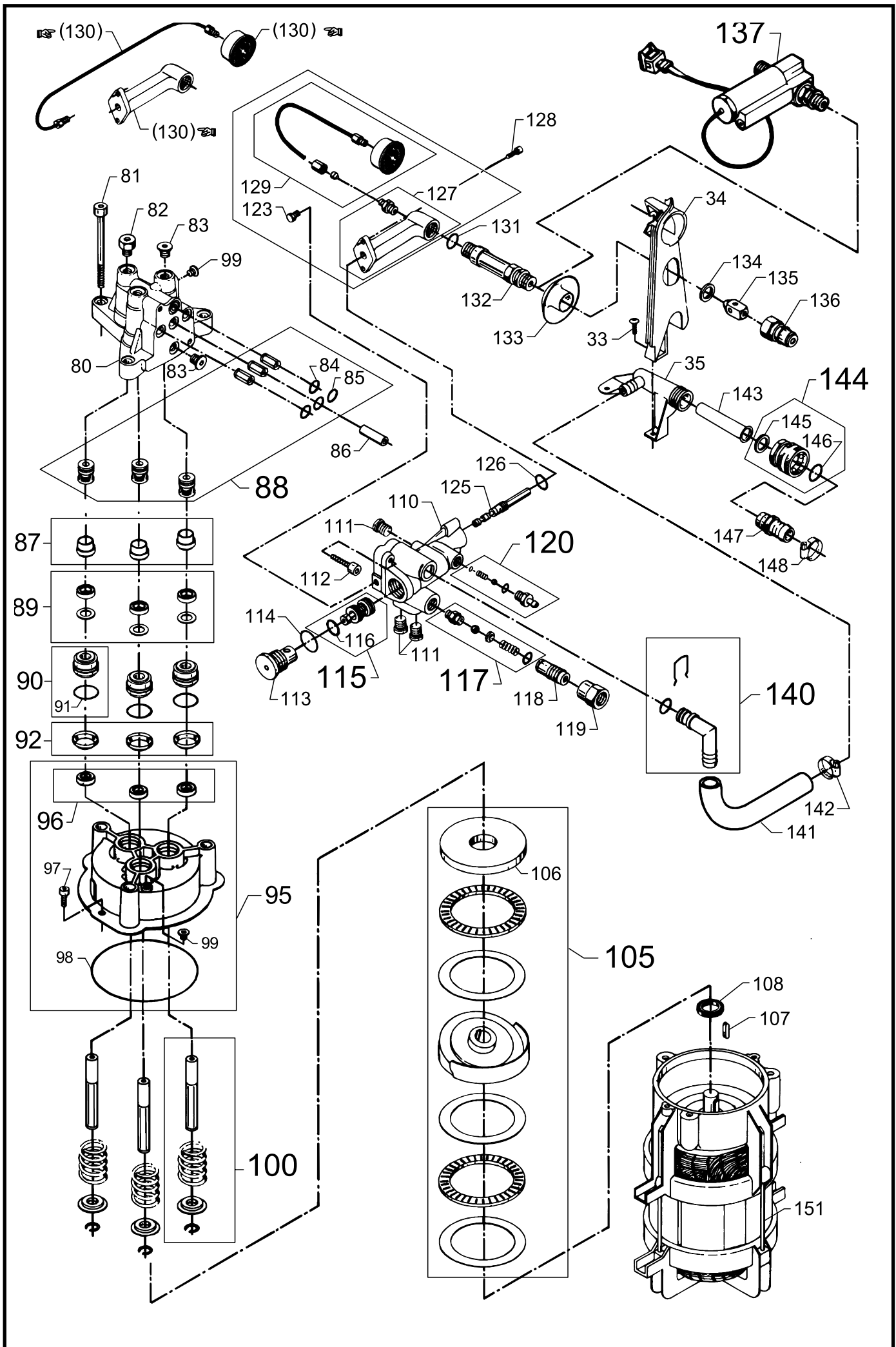

Pos. Ref.	Nr. No.	Betegnelse Bezeichnung	Designation Désignation					
				0940C	15-1740CA	2040C/CA	3340C/CA	4040CA
50	-	El-motor m. feder El. motor w. key (50) 60Hz El-motor m. Federkeil El. moteur a. clavette						
-	6183380	3x230 V, 60 Hz 3x220/440 V, 60 Hz USA, CDN						1
-	6183381	3x200 V, 50/60 Hz	J					1
-	6183383	3x200 V 50/60Hz	J				1	
-	6183389	1x115 V, 60 Hz USA, CDN		1				
-	6183388	1x220 V, 60 Hz			1			
-	6183387	1x220-230 V, 60 Hz USA, CDN				1		
74	-	El-kabel El.cable Anschlußkabel Câble électrique						
-	6180260	H07RN-F 4G 1.5 DK, S, NL, F, D, CH, A, U, B, I, E, N, SF (3X400V 50Hz) - GB,U,SGP,AUS(3x415-440V 50Hz)						3~
-	6180261	H07RN-F 3G 1.5 D,A,B,E,F, I,N,NL,F (1X230V 50Hz) - GB, SGP, AUS (1X240V 50Hz) - U(1X220V,60Hz)-SF(1X230V,50Hz)						1~
-	6180269	H07RN-F 3G 2.5 4040CA						Y/Δ
-	6180262	H07RN-F 3G 2.5 ROK, CN (1x220V)						
-	6180263	SOW-AWG 12/3 CDN (1X115V 60Hz)						
-	3821142	SJTW-AWG 12/3 USA (1X220V 60Hz)						
-	6180264	SOW-AWG 14/3 CDN (1x220V 60Hz)						
-	6180265	SOW-AWG 14/4 USA (3X220/440V, 60Hz)						
-	6180266	SVCT 4G2.0 Japan						
-	3821316	with GFCI-relay 20A -120V USA						
-	6180268	H07RN-F 3G4 GB (1x110V, 50 Hz)						

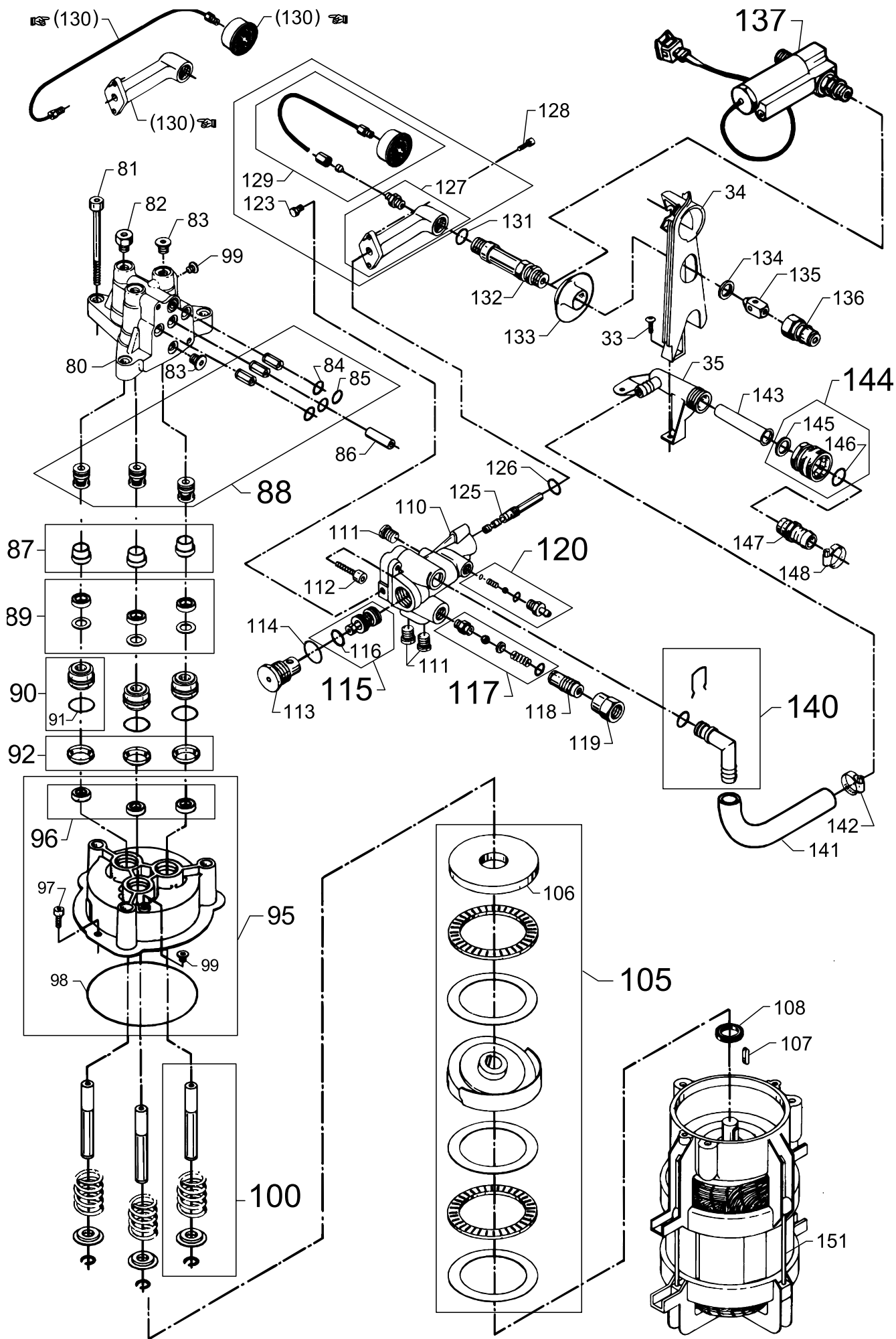

Pos. Ref.	Nr. No.	Betegnels Bezeichnung	Designation Désignation	0940C	15-1740C/CA	2040C/CA	3340C/CA	4040CA
80	6187132	Topstykke Cylinder head Zylinderkopf Culasse		1	1	1	1	1
81	1813393	Skrue Screw, Insex Schraube Vis	M 10x100	3	3	3	3	3
82	6180905	Forskruning m. O-ring Threaded connecton w. O-ring Verschraubung m. O-Ring Raccord a. joint torique		1	1	1	1	1
83	6180906	Prop m. O-ring Plug with O-ring Pflöfen mit O-Ring Manchon a. joint torique		3	3	3	3	3
84	3001807	O-ring O-ring O-Ring Joint torique		1	1	1	1	1
85	3001070	O-ring O-ring O-Ring Joint torique		3	3	3	3	3
86	6120624	Afstandsboening Spacer Distanzhülse Douille d'écartement		1	1	1	1	1
87	6183050	Afstandsstykke (3 stk.) Spacer (3 pcs.) Distanzstück (3 Stck.) Pièce d'espace (3 pcs.)		1	1	1	1	1
88	1119209	Rep.sæt, ventilsystem Rep.kit, valvesystem Rep.satz, Ventilsystem Kit de rép., système de clapet		x	x	x	x	x
89	1119212	Rep.sæt, Støttering/U-manchet Rep.kit, Back-up ring/U-seal Rep.satz, Stützring/U-Mansch. Kit, Anneau d'appui/U-raccord		1	1	1	1	1
90	6180910	Trykring, kompl. Thrust collar, compl. Druckring, Kompl. Anneau d'arrêt, compl.		3	3	3	3	3
91	3004009	O-ring O-ring O-Ring Joint torique		3	3	3	3	3
92	6183051	Afstandsstykke (3 stk.) Spacer (3 pcs.) Distanzstück (3 Stck.) Pièce d'espace (3 pcs.)		1	1	1	1	1
95	6180911	Cylinderblok, kompl. Cylinderblock, compl. Zylinderblock, kompl. Carter-cylindre, compl.		x	x	x	x	x
96	1117642	U-manchet (3 stk.) U-seal (3 pcs.) U-Manschette (3 Stck.) Joint d'huile (3 pcs.)		1	1	1	1	1
97	1814573	Skrue Screw Insex Schraube Vis	M 6x35	2	2	2	2	2
98	3003886	O-ring O-ring O-Ring Joint torique	ø120,4x1,78	1	1	1	1	1
99	6122313	Prop m. o-ring Plug with o-ring Pflöfen mit o-ring Manchon a. joint torique		2	2	2	2	2

Pos. Ref.	Nr. No.	Betegnels Bezeichnung	Designation Désignation	0940C	15-1740C/CA	2040C/CA	3340C/CA	4040CA
100	-	Rep.sæt, keramikstempel Rep.kit, ceramic piston Rep.satz, Keramis. druckkolben Kit de rép., piston ceramique						
100	1119201	1740C/A 2040C/CA,60Hz 1540C	1~		3	(3)		
100	1119202	0940C 2040C/CA,50/60Hz 3340C/CA 4040CA	3~		3	(3)	3	3
105	-	Rep.sæt, skråskive/lejer Rep.kit, wobble disc/bearings Rep.satz, Taumelscheibe/Lager Kit, disque oblique/roulements		x	x	x	x	x
-	1119224	1540C, 50Hz 1740C (110V)	⇒ 01.01.94		x			
-	1119647	1540C, 50Hz 1740C (110V)	01.01.94 ⇒		x			
-	1119226	1740C, 50Hz (220/230/240V)	⇒ 01.01.94		x			
-	1119648	1740C, 50 Hz (220/230/240V)	01.01.94 ⇒		x			
-	1119204	2040C/CA, 50Hz	⇒ 02.10.95			x		
-	1119682	2040C/CA, 50Hz	02.10.95 ⇒			x		
-	1119205	3340C/CA, 50Hz	⇒ 02.10.95				x	
-	1119686	3340C/CA, 50Hz	02.10.95 ⇒				x	
-	1119656	4040C/CA, 50Hz						x
-	1119205	0940C/CA, 60Hz PE, U, USA	⇒ 01.03.94	x				
-	1119649	0940C/CA, 60Hz PE, U, USA	01.03.94 ⇒	x				
-	1119206	1740C/CA, 60Hz	⇒ 01.03.94		x			
-	1119650	1740C/CA, 60Hz	01.03.94 ⇒		x			
-	1119207	2040C/CA, 60Hz, 3~	⇒ 02.10.95			x		
-	1119651	2040C/CA, 60Hz, 3~	02.10.95 ⇒			x		
-	1119207	2040C/CA, 60Hz, 1~	⇒ 01.03.94			x		
-	1119651	2040C/CA, 60Hz, 1~	01.03.94 ⇒			x		
-	1119208	0940C, 60Hz CDN	⇒ 01.03.94	x				
-	1119652	0940C, 60Hz CDN	01.03.94 ⇒	x				
-	1119208	3340C/CA, 60Hz	⇒ 02.10.95				x	
-	1119687	3340C/CA, 60Hz	02.10.95 ⇒				x	
-	1119655	4040C/CA, 60Hz						x
106	6181518 6182479	Lejeskive Bearing track, 3~ Lagerscheibe Rondelle de palier	⇒ 02.10.95 02.10.95 ⇒	1	1	1	1	1
-	6181518	1~, 50Hz	⇒ 01.01.94	1	1	1	1	
-	6181518	1~, 60Hz	01.03.94	1	1	1	1	
-	6182479	1~, (3~) 50Hz	01.01.94 ⇒	1	1	1	1	(1)
-	6182479	1~, (3~) 60Hz	01.03.94 ⇒	1	1	1	1	(1)
107	3202421	Feder Key Federkeil Clavette		1	1	1	1	1
108	1119671	Rep.sæt, akseltætningsring Rep.kit, sealing ring for shaft Rep.satz, Wellendichtungsring Kit de rép., joint annulaire p. arbre		1	1	1	1	1
110	6181477	Ventilhus Valve housing Ventilgehäuse Carter-by pass		1	1	1	1	1
111	6180913	Blændprop m. o-ring Hole plug w. o-ring Verschlußpfropfen m. o-Ring Bouchon a. joint torique		3	3	3	3	3
112	1803345	Skrue Screw Insex Schraube Vis	M 8x30	2	2	2	2	2



Pos. Ref.	Nr. No.	Betegnels Bezeichnung	Designation Désignation	0940C	15-1740C/CA	2040C/CA	3340C/CA	4040CA
113	6180650	Prop Plug Pfropfen Bouchon		1	1	1	1	1
114	3001963	O-ring O-ring O-Ring Joint torique		1	1	1	1	1
115	-	Ventilkegle, kompl. Piston, compl. Kolben, Kompl. Piston, compl., by pass		1	1	1	1	1
-	6180914	0940C, 1540C 1740C/CA 2040C/CA		1	1	1		
-	6180915	3340C/CA 4040CA					1	1
116	3003860	O-ring O-ring O-Ring Joint torique		1	1	1	1	1
117	1118512	Rep.sæt, sikkerhedsventil Rep.kit, Safety valve Rep.satz, Sicherheitsventil Kit de rép., soupape de sûreté		x	x	x	x	x
118	6100940	Justerskrue Adjustment screw Justierschraube Vis de réglage		1	1	1	1	1
119	6100928	Kontramøtrik Lock nut Gegenmutter Contre écrou		1	1	1	1	1
120	1119406	Rep.sæt, kontraventil Rep.kit, non return valve Rep.satz, Rückschlagventil Kit de rép., clapet anti retour		x	x	x	x	x
123	6181542	Blændprop Hole plug Verschlußpfropfen Bouchon		1	1	1	1	1
125	6180916	Injektordyse m. o-ring Injectornozzle w. o-ring Injektordüse m. o-Ring Buse de l'injecteur a. joint torique		1	1	1	1	1
126	3001674	O-ring O-ring O-Ring Joint torique		1	1	1	1	1
127	6180923	Afgangsrør, kompl. Outlet pipe, compl. Auslaßrohr, kompl. Tuyau de départs, compl.		1	1	1	1	1
128	1813484	Skrue Screw Insex Schraube Vis	M 6x162	2	2	2	2	2
129	6180946	Manometer, kompl. Pressure gauge, compl. Manometer, kompl. Manomètre, compl.		1	1	1	1	1
130	1119692	Opgraderingskit f. manometer Upgrade kit f. pressure gauge Aufgradierungssatz f. Manometer Kit d'amélioration p. manomètre		1	1	1	1	1
			For renserer produceret for 02.03.92 For cleaners produced until 02.03.92 Für reiniger, die bis 02.03.92 hergestellt worden sind Pour les appareils fabriqués avant 02.03.92					
131	3002029	O-ring O-ring O-Ring Joint torique		1	1	1	1	1
132	6181546	Bøsning Bush Buchse Baque		1	1	1	1	1

Pos. Ref.	Nr. No.	Betegnels Bezeichnung	Designation Désignation	0940C	15-1740C/CA	2040C/CA	3340C/CA	4040CA
133	6180707	Gummi manchet Rubber seal Gummimanschette Joint à lèvre, caoutch.		1	1	1	1	1
134	1801075	Tætningsskive Tightening gasket Dichtungsscheibe Rondelle d'étanchéité		1	1	1	1	1
135	6101038	Stempel Piston Kolben Piston		1	1	1	1	1
136	1600493	Lynkoblingsnippel (højtryk) Nipple f. quick coupling Schnellkupplungsnippel (H.D.) Entre du coupleur rapide		1	1	1	1	1
136	1603101	Lynkoblingsnippel , RF (højtryk) Nipple f. quick coupling, SS Schnellkupplungsnippel, RF (H.D.) Entre du coupleur rapide, INOX		1	1	1	1	1
137	6180414	Strømningskontakt Flow switch Strömungsschalter Circulation sélecteur	40CA					
				Se side 13 See page 13 Siehe Seite 13 Voir page 13				
140	1119210	Rep.sæt, tilgangsvinkel Rep.kit, inlet elbow Rep.satz, Einlaßwinkel Kit de rép., Coude du entrée		x	x	x	x	x
141	2450000	Intern tilgangsslange Internal inlet hose Interner Einlaßschlauch Admission eau, intérieure		1	1	1	1	1
142	1802107	Spændebånd Hose clip Schlauchschele Collier de serrage		1	1	1	1	1
143	6100941	Filter Filter Filter Filtre		1	1	1	1	1
144	1602945	Lynkobling, kompl. Quick coupling, compl. Schnellkupplung, kompl. Coupleur rapide, compl.		1	1	1	1	1
145	3001237	Pakning Gasket Dichtung Joint		1	1	1	1	1
146	3000320	O-ring O-ring O-Ring Joint torique		1	1	1	1	1
147	1600659	Lynkoblingsnippel (lavtryk) Nipple f. quick coupling (L.P.) Nippel f. Schnellkupplung (N.D.) Entre du coupleur rapide		1	1	1	1	1
147	1605955	Lynkoblingsnippel (lavtryk) USA, CDN Nipple f. quick coupling (L.P.) Nippel f. Schnellkupplung (N.D.) Entre du coupleur rapide		1	1	1	1	1
148	1802107	Spændebånd Hose clip Schlauchschele Collier de serrage		1	1	1	1	1
151	6180939	Stagbolt Stud Stehbolzen Entreboise		4	4	4	4	4
-	5218433	„Castrol, Alphasyn -T“ ISO 150 (1 x 1L) (4040CA)						
-	5218602	Pump oil HV68 (1 x 1L)						
-	-	Instruktionsbog Instruction manual Betriebsanleitung Livret d'instructions		x	x	x	x	x
-	6189030	DK-N-S-SF						
-	6189031	GB-D-F-NL-E						
-	6189032	USA						
-	6189033	(F-GB-E)						

El-kasse / Connection box / Electrogehäuse / Boîtier électrique
 40CA ⇒ 01.04.95 |

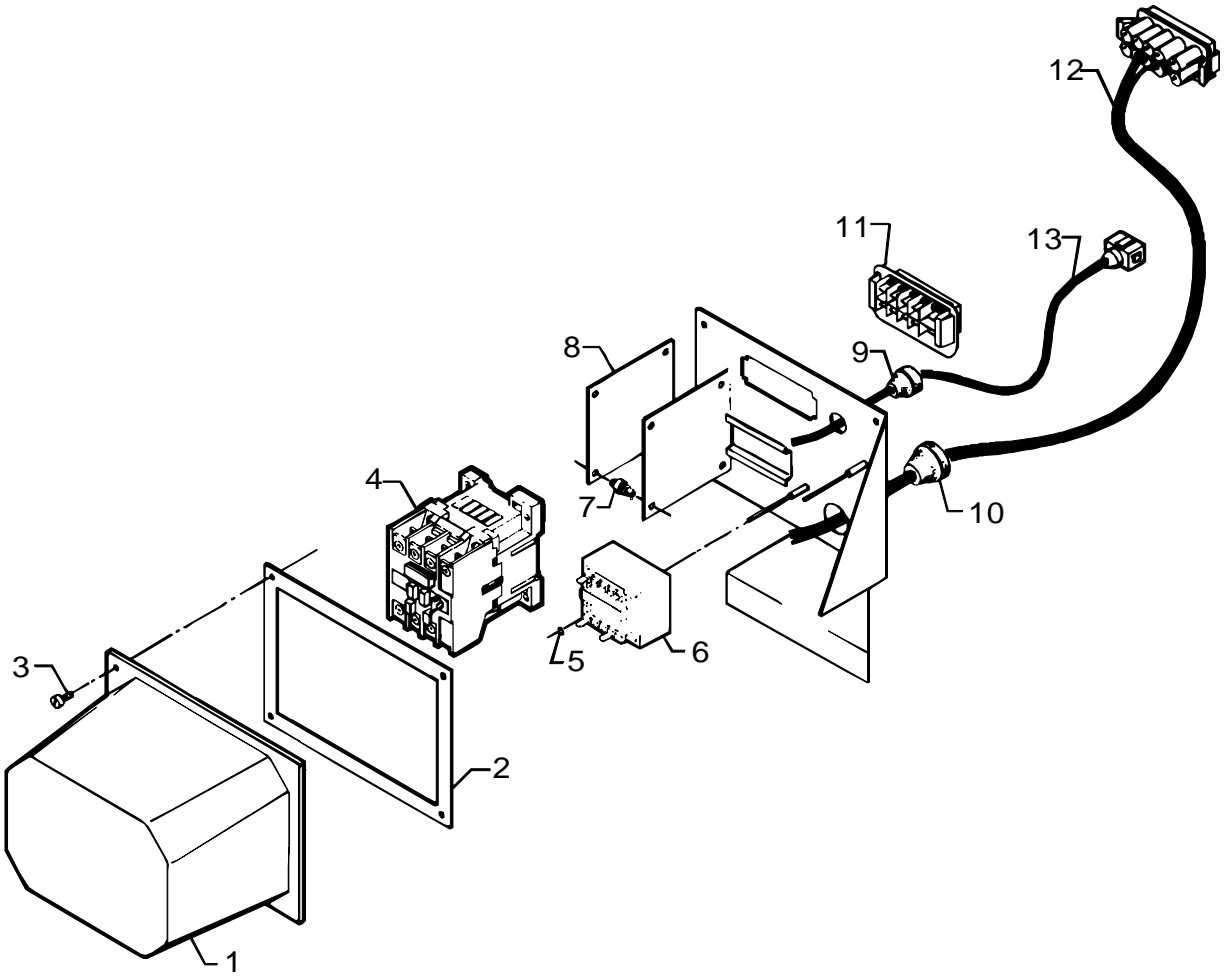

Strømningskontakt. / Flow switch / Strömungsschalter / Circulation sélecteur
 40CA ⇒ 01.04.95 |

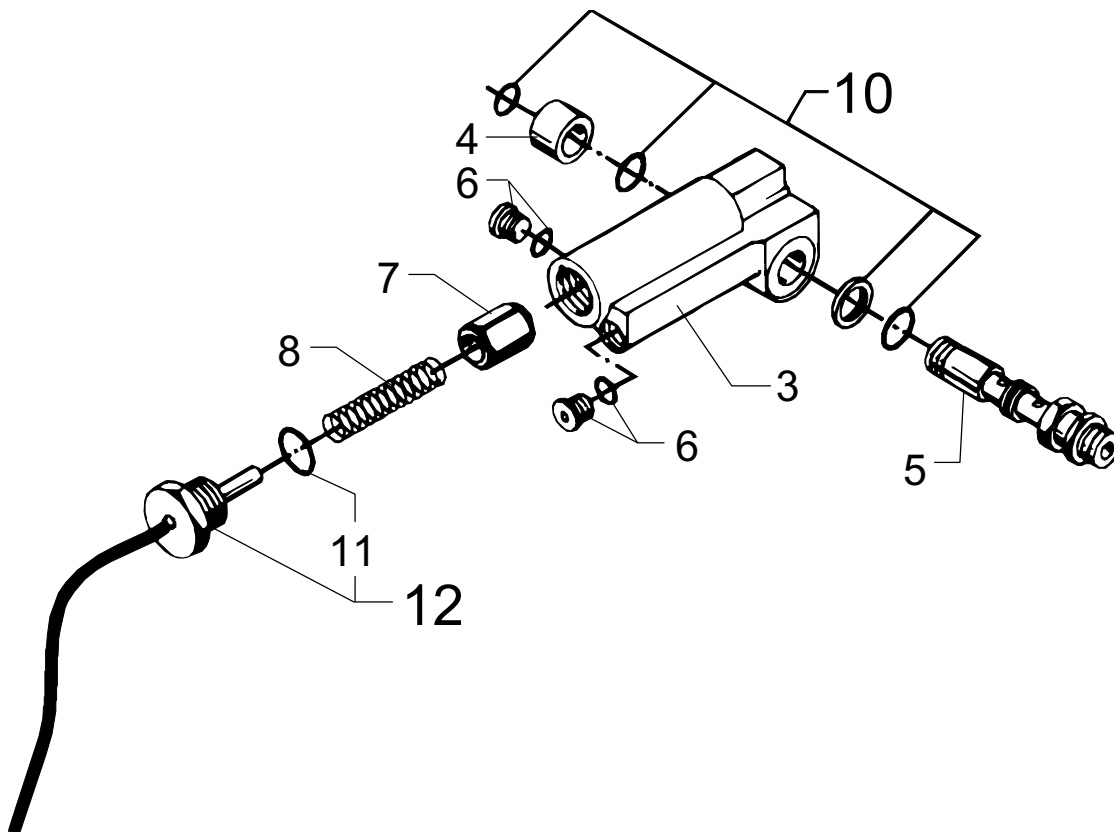

Pos. Ref.	Nr. No.	Betegnels Bezeichnung	Designation Désignation	0940C	15-1740C/CA	2040C/CA	3340C/CA	4040CA
48	-	El-kasse, kompl. Connection box Electrogehäuse, kompl. Boîtier électrique, compl.	40CA		CA	CA	CA	CA
-	1119614	3x380V 50Hz	Y					
-	1119615	3x415-440V 50/60Hz	Y					
-	-	3x200V 50/60Hz	Δ					
-	-	3x220V 60Hz	Δ					
-	1119618	3x230V 60Hz	Δ					
-	-	3x380/220V 50Hz	Y/Δ					
-	-	3x440/220V 60Hz	Y/Δ					
-	-	1x220V 50/60Hz						
-	-	1x240V 50Hz						
-	-	1x220V 60Hz	USA					
1	6222747	Låg for el-kasse Cover for connection box Deckel für Elektrogehäuse Couvercle pour Boîtier électrique		1	1	1	1	1
2	6222749	Pakning Gasket Dichtung Joint		1	1	1	1	1
3	1803956	Taptite skrue Taptite screw Taptiteschraube Vis Taptite	M4x12	4	4	4	4	4
4	3804051	Kontaktor 24V, CA3 - 16 - 10 Contactor Schütz Contacteur						
4	3804168	Kontaktor 24V, CA3 - 23 - 10 Contactor Schütz Contacteur	⇒ 31.12.99					
4	63907	Kontaktor 23A 24V 50-60HZ Contactor Schütz Contacteur	01.01.00 ⇒					
5	1805563	Låseskive Lock washer Federtellerscheibe Circlip		2	2	2	2	2
6	-	Styretransformer Control transformer Steuerungstransformer Transformateur commande	24V					
-	3819760	Sec. 24V / Prim. 3x220V						
-	3819778	Sec. 24 V / Prim. 3x230V						
-	3819786	Sec. 24 V / Prim. 3x380V						
-	3819794	Sec. 24 V / Prim. 3x415-440V						
-	3819844	Sec. 24 V / Prim. 3x200V						
-	3821327	Sec. 24 V / Prim. 220/380V						
-	3821328	Sec. 24 V / Prim. 220/440V						
7	3821318	Printstag Plug f. circuit board Stecker f. Print Prise p. circuit imprimé		4	4	4	4	4
8	6420012	Automatisk start/stop Automatic start/stop Start/Stop Automatik Marché/ arrêt auto.		1	1	1	1	1
9	3803764	Pakdåse Cable grommet Stopfbuchse Presse-étoupe	TET 5-7C	1	1	1	1	1
10	3803780	Pakdåse Cable grommet Stopfbuchse Presse-étoupe	TET 10-14	1	1	1	1	1

Pos. Ref.	Nr. No.	Betegnels Bezeichnung	Designation Désignation	0940C	15-1740C/CA	2040C/CA	3340C/CA	4040CA
-	3803798	Pakdåse Cable grommet Stopfbuchse Presse-étoupe	(110/115V) TET 14-20C	1	1	1	1	1
11	-	Motorstik (han) Motor plug (male) Motorstecker (außen) Fiche moteur (mâle)						
-	3820214	Sjærnekobling Star connection Sternschaltung Étoile-commutation	Y					
-	3820206	Trekants-kobl. Delta connection Dreieckschalter Triangle-commutation	Δ					
-	3820222	Omkoblingsstik (han) Change-over plug (male) Umschaltstecker (außen) Fiche de commutation (mâle)						
12	3821276	Kabel f. el- kasse Cable f. connection box Kabel f. Elektrogehäuse Câble p. boîtier électrique	Y el. Δ Y or Δ Y oder Δ Y ou Δ					
12	3821319	Kabel f. el- kasse Cable f. connection box Kabel f. Elektrogehäuse Câble p. boîtier électrique	Y/Δ					
13	3821277	Ledning m. stik (han) Cable w. plug (male) Leitung m. Stecker (außen) Câble a. prise (mâle)						
-	6409106	Monteringsvejledning Mounting instructions Montageanleitung Instructions de montage	40CA	CA	CA	CA	CA	CA
137	6180414	Strømningskontakt, kompl. Flow switch, compl Strömungsschalter, kompl. Circulation sélecteur, compl.		x	x	x	x	x
3	6401825	Hus Housing Gehäuse Carter		1	1	1	1	1
4	6181473	Afstandsstykke Spacer Zwischenstück Pièce d'espace		1	1	1	1	1
5	6181474	Bøsning f. vandafgang Bush f. water outlet Buchse f. Wasserauslaß Baque		1	1	1	1	1
6	6180913	Blændprop m. O-ring Plug with O-ring Pfropfen mit O-Ring Manchon avec joint torique		2	2	2	2	2
7	6350454	Stempel, kompl. Piston, compl. Kolben, kompl. Piston, compl.		1	1	1	1	1
8	2602373	Fjeder Spring Feder Ressort		1	1	1	1	1
10	1119283	Rep. sæt, O-ring / tætningsskive Rep. kit O-ring / sealing washer Rep. satz, O-Ring / Dichtungsscheibe Kit de rép., joint torique / rondelle		1	1	1	1	1
11	3000825	O-ring O-ring O-Ring Joint torique		1	1	1	1	1
12	1119817	Reedkontakt m. O-ring Reed switch with O-ring Reedschalter mit O-ring Reed sélecteur avec joint torique		1	1	1	1	1