

03KO
03KOS

ALTO®

Total Cleaning
Confidence™



Reserve de le
Spare parts
Ersatzteile
Pièces détachées

598 51 31 - Mar. 2002

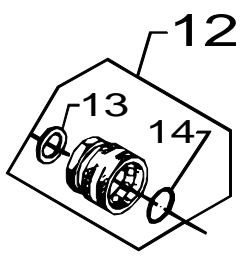
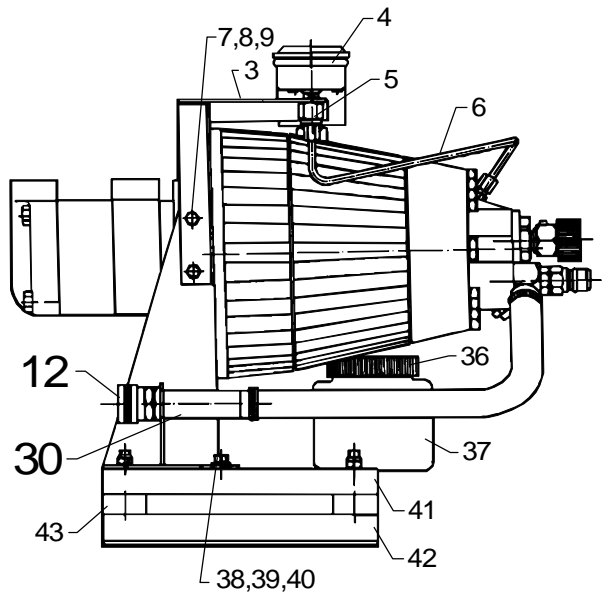
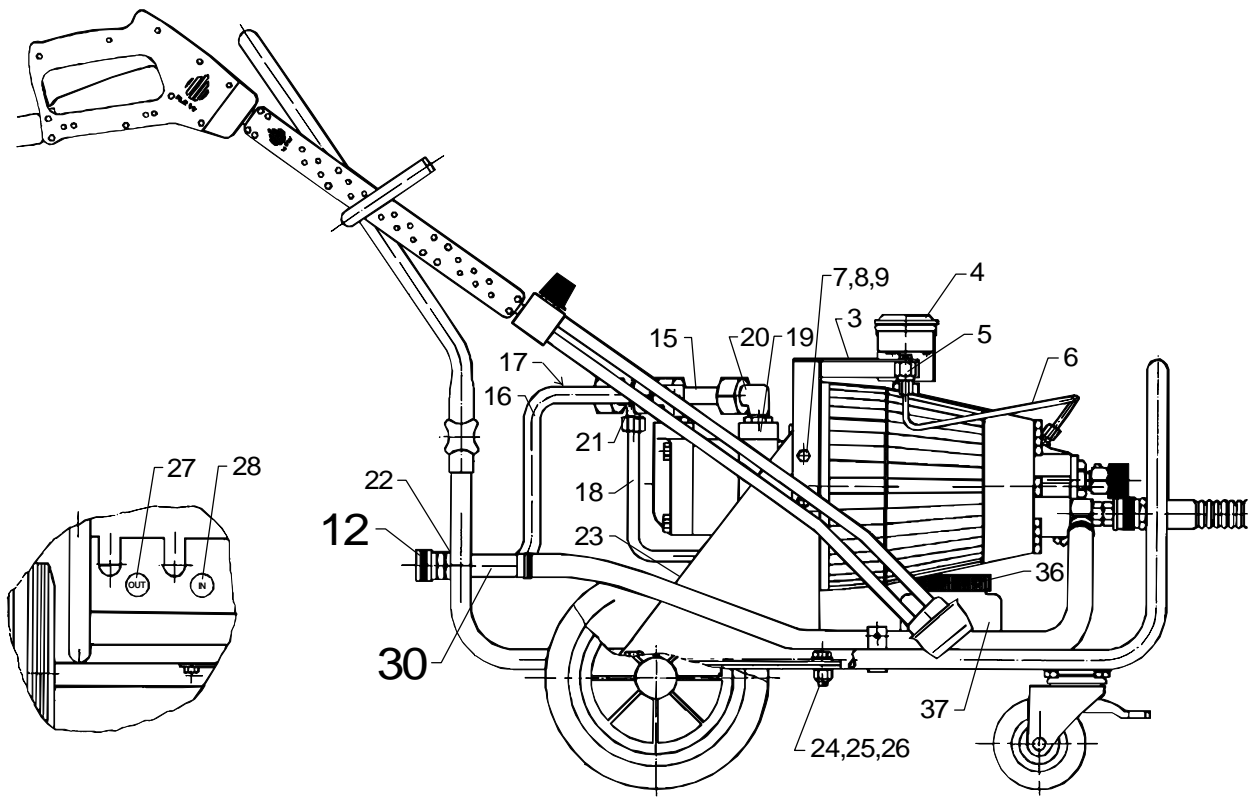

30

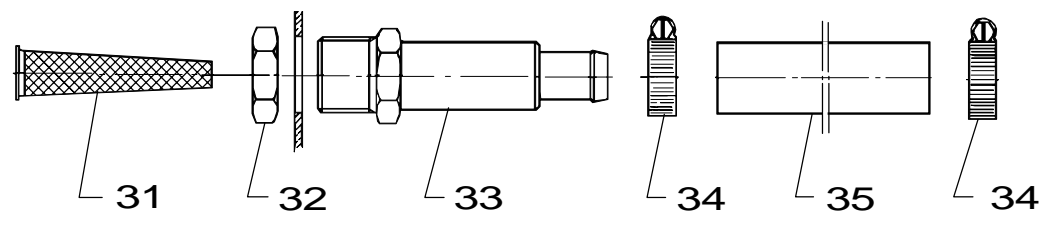

Pos. Ref.	Nr. No.	Betegnels Bezeichnung	Designation Désignation	03KO	03KOS
-	-	Motorpumpeenhed i stel Motor/pump unit in chassis Motorpumpeneinheit im Rahmen Unité de moteur/pompe en châssis		x	x
3	6167902	Manometerholder Attachment f. pressure gauge Halter f. Manometer Support p. manomètre		1	1
4	3601262	Manometer Pressure gauge Manometer Manomètre		1	1
5	1600535	Manometertilslutning Pressure gauge connection Manometeranschluß Raccord p. manomètre		1	1
6	6162914	Manometerrør, komplet Pressure gauge pipe, compl. Manometerrohr, kompl. Tuyau - pression, compl.		1	1
7	1800432	Sætskrue Set screw Gewindestift Vis de bloquage		2	2
8	1802875	Fjederskive Spring washer Federscheibe Rondelle ressort		2	2
9	1800705	Møtrik Nut M6 Mutter Écrou		2	2
12	1602945	Lynkobling, kompl. Quick coupling, compl. Schnellkupplung, kompl. Coupleur rapide, compl.		1	1
13	3001237	Pakning Gasket Dichtung Joint		1	1
14	3000320	O-ring O-ring O-Ring Joint torique		1	1
15	6167903	Rør, afgang I Tube, outlet I Rohr, Auslaß I Tuyau, de décharge I		1	
16	6167904	Rør, tilgang Tube, admission Rohr, Einlaß Tuyau, admission		1	
17	6167905	Rør, afgang II Tube, outlet II Rohr, Auslaß II Tuyau, de décharge II		1	
18	6167906	Rør Tube Rohr Tuyau		1	
19	1600618	Nippelmuffe Pipe bushing Nippelmuffe Manchon de réduction		2	
20	1604271	Vinkel Elbow Winkel Coude		2	
21	1604289	T-stykke T-piece T-Stück Pièce à T		1	
22	1603168	Forskruning Threaded connection Verschraubung Raccord fileté		1	
23	1600444	Vinkel Elbow Winkel Coude		1	

Pos. Ref.	Nr. No.	Betegnels Bezeichnung	Designation Désignation	03KO	03KOS
24	1801133	Sætskrue Set screw M10x25 Gewindestift Vis de bloquage		4	
25	1800317	Skive Washer M10 Scheibe Rondelle		4	
26	1801257	Låsemøtrik Lock nut M10 Gegenmutter Écrou de blocage		4	
27	6167924	Transfer Transfer "out" Aufkleber Autocollant		1	
28	6167923	Transfer Transfer "in" Aufkleber Autocollant		1	
30	-	Vantilgang, kompl. Water, inlet, compl. Wassereinflaß, kompl. Tube d'admission, compl.		x	x
31	6100941	Filter Filter Filter Filtre		1	1
32	1800341	Kontramøtrik Lock nut Gegenmutter Contre écrou		1	1
33	6100937	Filterhus Housing f. filter Filtergehäuse Gaine de filtre d'eau		1	1
34	1802107	Spændebånd Hose clip Schlauchschelle Collier de serrage		2	2
35	5206230	Slange Hose Schlauch Tuyau	(L=780)	1	
-	5206230	Slange Hose Schlauch Tuyau	(L=360)		1
36	6101625	Slamglaslæg Cover f. sludge container Deckel f. Schlammglas Couvercle, resv. d'huile use		1	1
37	2200467	Slamglas Sludge container Schlammglas Reservoir d'huile usée		1	1
38	1800465	Møtrik Nut M10 Mutter Écrou			2
39	1800309	Fjederskive Spring washer Federscheibe Rondelle ressort			2
40	1801133	Sætskrue Set screw Gewindestift Vis de bloquage			2
41	6168907	Konsol, top Bracket, top section Konsole, oberes Teil Console, part supérieure			2
42	6168912	Konsol Bracket Konsole Console			1
43	1801240	Svingningsdæmper Vibration damper Schwingungsdämpfer Amortisseur de vibration			4

598 51 31 - Mar. 2002

⚠ **ATTENTION!** - Lengths in metres - Please indicate required length when ordering!
⚠ **ACHTUNG!** - Meterware - Bitte bei Bestellung gewünschte Länge angeben!

⚠ **ATTENTION!** - Longueurs par mètre - Préciser la longueur à la commande!
⚠ **BEMERK!** - Meterware - Vær venlig at oplyse længde ved bestilling!

03KO

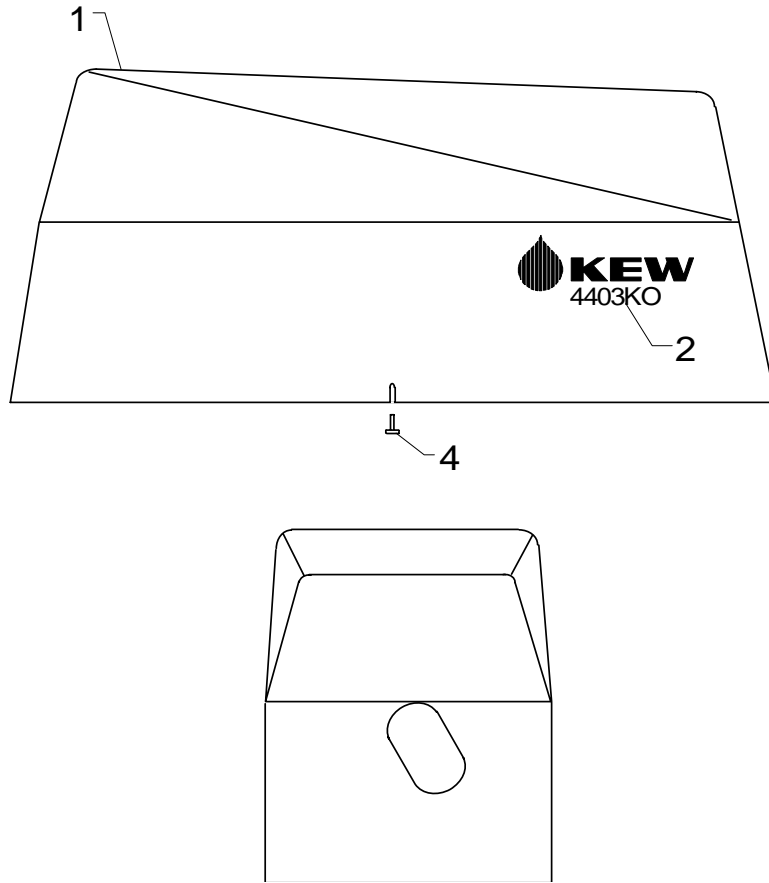

03KO

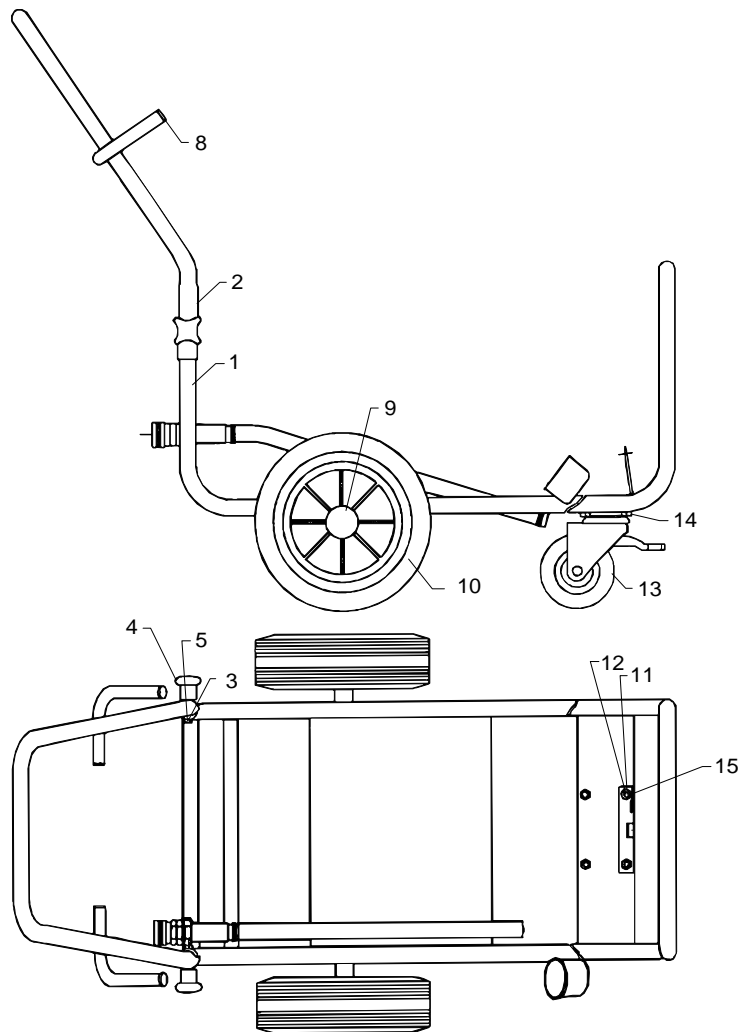

03KO

03KOS

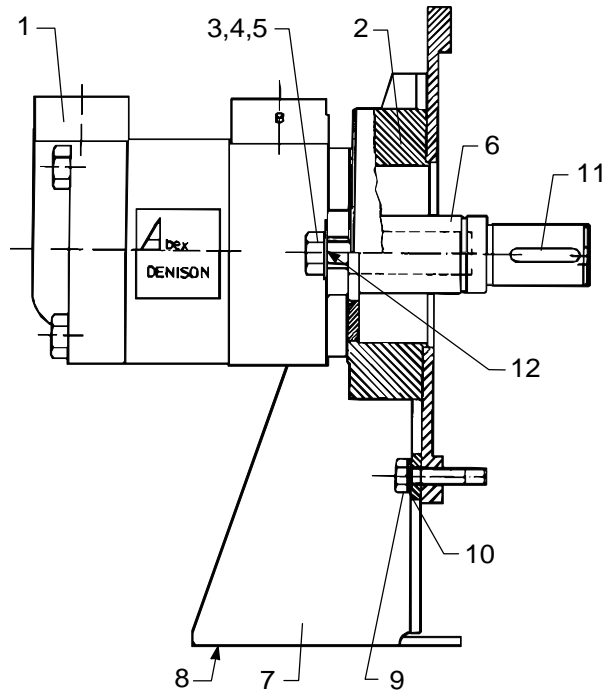
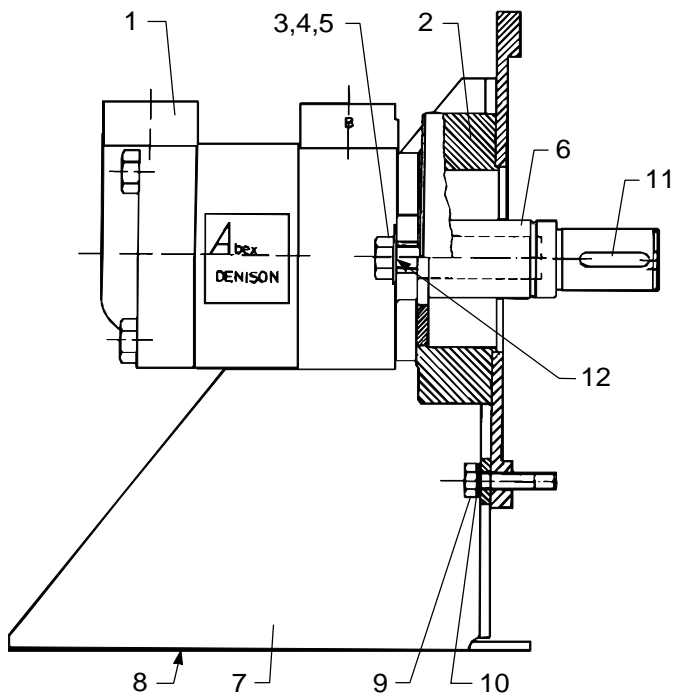

- A 6109046
- A₂ 1119568
- B 1119035
- C 1119820
- D 1119310
- E 1118538
- F 1118520
- G 1118512

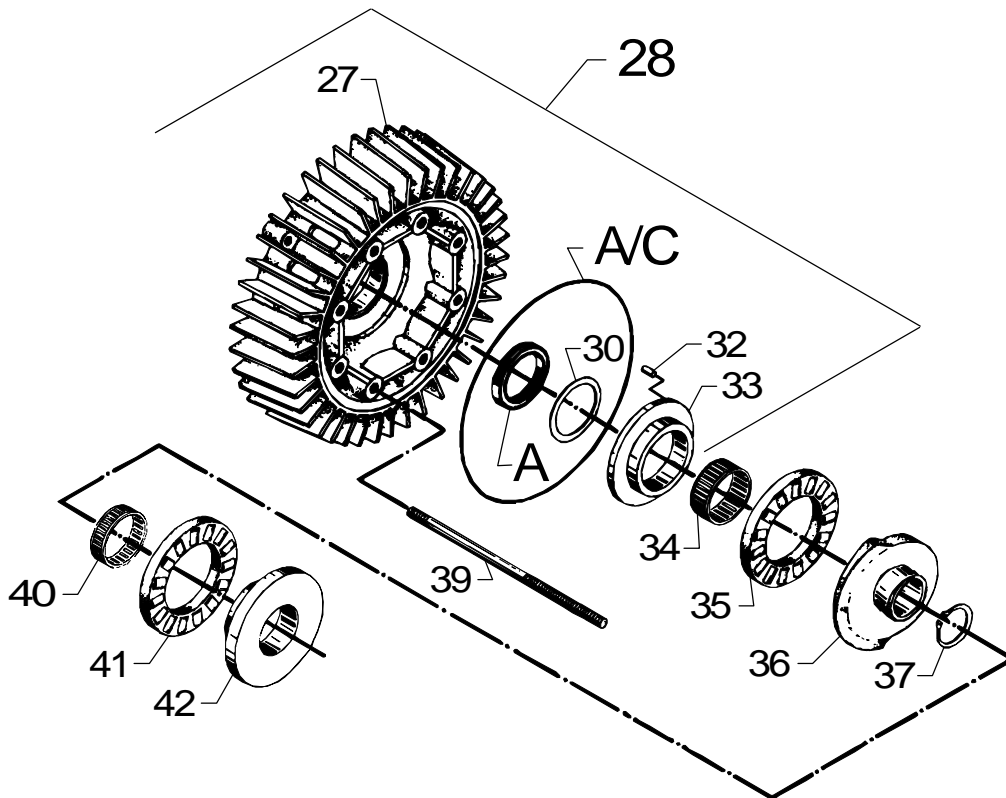

- A 6109046
- A₂ 1119568
- B 1119035
- C 1119820
- D 1119310
- E 1118538
- F 1118520
- G 1118512

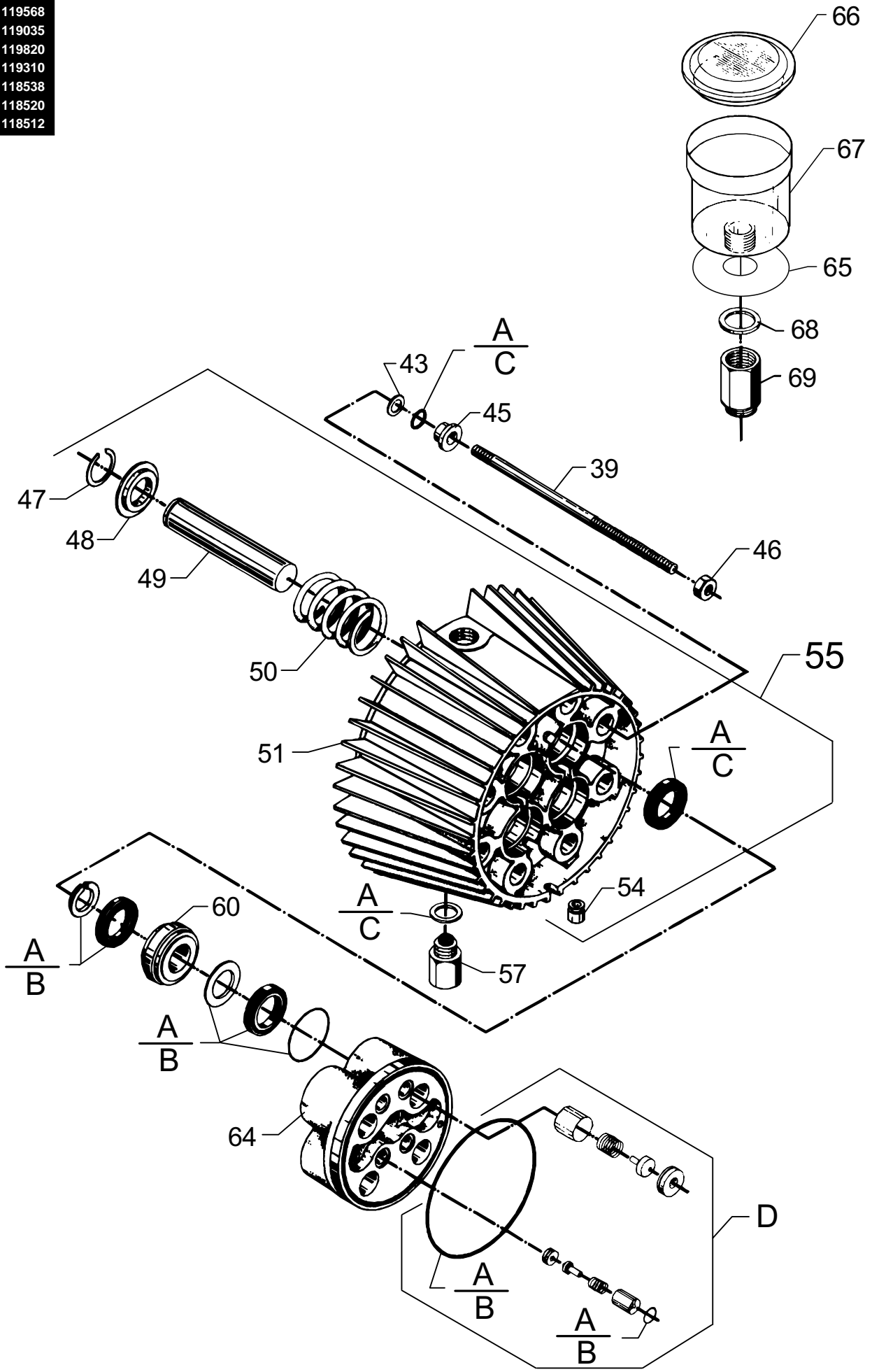

A	6109046
A ₂	1119568
B	1119035
C	1119820
D	1119310
E	1118538
F	1118520
G	1118512

